

**SEZIONE ATTREZZI
TOOLS SECTION**

bwz-zett[®]



PIAGGIO - VESPA - APRILIA - GILERA



**CHIAVI PER CANDELE E RUOTE
SPANNERS FOR PLUG AND WHEEL**

Conf. / Pack 2 pcs

Art. 4870

Es. - hex. mm. 11 x 13 x 21
**VESPA SPECIAL model
PRIMAVERA - ET3 model**

Art. 4874

Es. - hex. mm. 13 x 17 x 21
**VESPA SPECIAL model
PRIMAVERA - ET3 model**

Art. 4881

Es. - hex. mm. 13 x 11 x 21
**VESPA SUPER - SPRINT
PX - PE model**

Art. 4827

CHIAVE CANDELA CON GOMMINO
SPARK PLUG SPANNER WITH RUBBER

L= mm 115 Es. - hex. mm. 16

VESPA PRIMAVERA 125/150 4t 3V

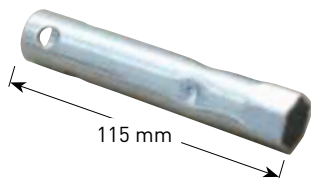

NEW

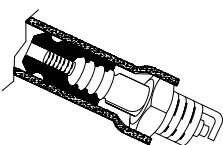

Art. 5232

ESTRATTORE VOLANO
FLY-WHEEL PULLER

Ø mm. 26 passo-pitch 1

PIAGGIO -VESPA 50 2t/4t

**APRILIA - PEUGEOT - 50CC 2t/4t
(KOKUSAN - MITSUBA)**

Conf. / Pack 2 pcs



Art. 5242

ESTRATTORE VOLANO
FLY-WHEEL PULLER

Ø mm. 28 passo-pitch 1

PIAGGIO - GILERA

50/125/150/200 2t - 4t

LML - 125 - 150 - 200

(MOTOPLATT)

Conf. / Pack 2 pcs



Art. 5255

ESTRATTORE VOLANO
FLY-WHEEL PULLER

Ø mm. 17 passo-pitch 1

CIAO - SI

Conf. / Pack 1 pc



Art. 5260

ESTRATTORE VOLANO
FLY-WHEEL PULLER

Ø mm. 24 passo-pitch 1

VESPA PK

Conf. / Pack 1 pc



Art. 5283

ESTRATTORE CON DOPPIO FILETTO ESTERNO DESTRO
PULLER WITH DOUBLE RIGHT OUTER THREAD

Ø mm. 26 passo-pitch 1

Ø mm. 28 passo-pitch 1

PIAGGIO - VESPA 125/150 2t - 4t

Conf. / Pack 2 pcs



Art. 5336

ESTRATTORE VOLANO FILETTO INTERNO
FLY-WHEEL PULLER WITH INTERNAL THREAD

Ø mm.35 passo-pitch 1

PER MOTORI/FOR ENGINES

PIAGGIO 250/300/400/500 4t

Conf. / Pack 1 pc



Art. 5337

ESTRATTORE VOLANO FILETTO INTERNO COMPLETO DI PUNTALE
FLY-WHEEL PULLER WITH INTERNAL THREAD COMPLETE WITH ROD

Ø mm. 30 passo-pitch 1

PER/FOR **VESPA PRIMAVERA 125-150cc**

DAL/FROM 2014

VESPA SPRINT 125 - 150cc

PIAGGIO LIBERTY 125 - 150cc

MOTORI / ENGINES 4t 3V

VESPA LX - S 125 - 150 4t

Conf. / Pack 1 pc



PIAGGIO - VESPA - APRILIA - GILERA

Art. 5421

ESTRATTORE SMONTAGGIO FRIZIONE
PULLER FOR CLUTCH DISASSEMBLING

Ø mm. 26 passo-pitch 1

VESPA 50

PRIMAVERA - ET3 125

VESPA PK 50/125

Conf. / Pack 2 pcs



Art. 5424

SPINGIDISCHI PER SMONTAGGIO FRIZIONE
PLATE PUSHING TOOL FOR CLUTCH DISASSEMBLY

VESPA 50/125/150/200

(O.R. 0030631)

Conf. / Pack 1 pc



Art. 5429

ATTREZZO PER SMONTAGGIO GHIERA FRIZIONE
TOOL FOR DISASSEMBLY CLUTCH RING NUT

VESPA PX - PE

(O.R. TOC30627)

Conf. / Pack 1 pc



Art. 5433

ATTREZZO SMONTAGGIO RUBINETTO BENZINA
TOOL FOR DISASSEMBLY PETROL TWIST GRIPS

VESPA

TUTTI I MODELLI / ALL MODELS

Conf. / Pack 1 pc



Art. 5419

ATTREZZO PER SERRAGGIO GHIERA STERZO
TOOL FOR TIGHTENING THE STEERING NUT

SCOOTERS PIAGGIO - GILERA



CHIAVI SMONTAGGIO FILTRI OLIO

OIL FILTERS TOOLS

Art. 5186

PER FILTRI Ø 76 CON 14 ANGOLI - INNESTO QUADRO

FOR FILTERS Ø 76 WITH 14 FLUTES - SQUARE CLUTCH

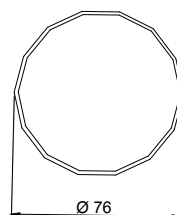

Art. 5197

PER FILTRI Ø 76 CON 12 INNESTI RIGATI

FOR FILTERS Ø 76 WITH 12 SCORED CLUTCHES

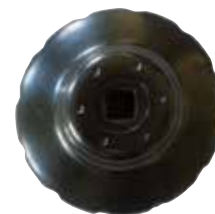
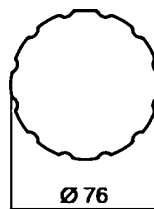

Art. 5106

ATTREZZO PER FILTRO MOTORI PIAGGIO 300-400-500cc 4t

DOPPIO USO Ø 76

PER CARTUCCE POLIGONALI E A INNESTI RIGATI

PIAGGIO 300-400-500cc 4s ENGINES FILTER TOOL

DOUBLE USE Ø 76

FOR SCORED CLUTCHES AND POLYGONAL CARTRIDGES

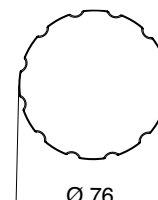
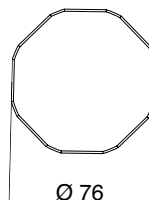

PIAGGIO - VESPA - APRILIA - GILERA

Art. 5110

ATTREZZO SMONTA FILTRO OLIO
MOTORI PIAGGIO da 125 a 300 cc. 4t
Ø 49 mm CON 14 INNISTI

PIAGGIO ENGINES from 125 to 300 cc. 4s
 OIL FILTER DISASSEMBLING TOOL
Ø 49 mm - 14 FLUTES

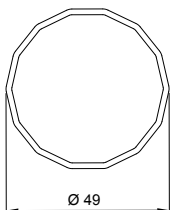

Art. 5437

ATTREZZO BLOCCA PULEGGIA ANTERIORE
 FRONT PULLEY LOCKING TOOL

MOTORI / ENGINES 4t 3V
VESPA PRIMAVERA 125-150cc
VESPA SPRINT 125 - 150cc
PIAGGIO LIBERTY 125 - 150cc

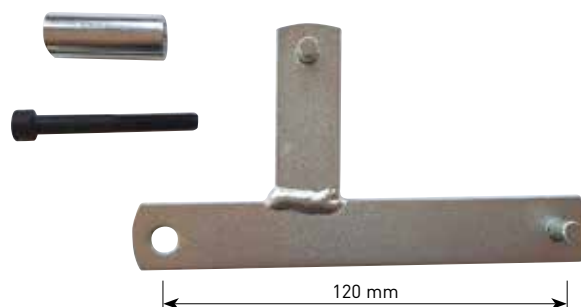

Art. 5112

ATTREZZO PER FILTRO
MOTORI PIAGGIO da 125 a 250 cc.

PIAGGIO ENGINES from 125 to 250 cc.
 FILTER TOOL

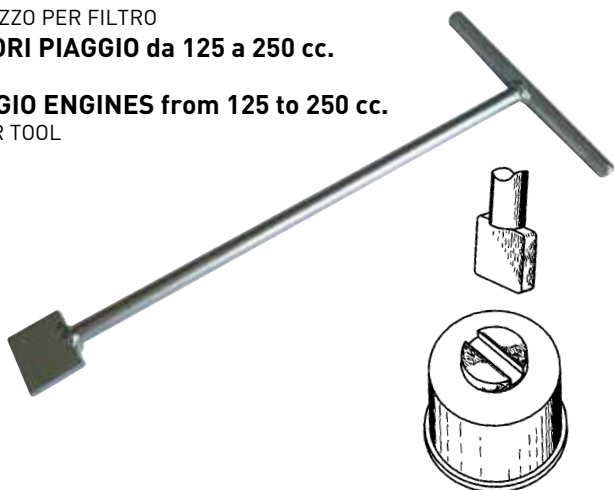

Art. 5440

ATTREZZO BLOCCA PULEGGIA ANTERIORE
 FRONT PULLEY LOCKING TOOL

PER MOTORI / FOR ENGINES
PIAGGIO 125/150 4t 3V

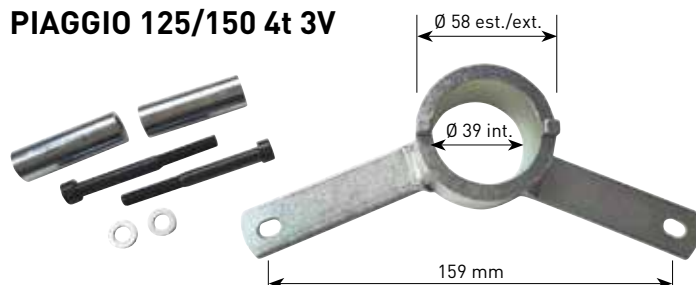

Art. 5427

ATTREZZO PER BLOCCARE LA FRIZIONE E PER LO SMONTAGGIO
 DEL DADO CON ESAGONO **mm 34**

HOLDING TOOL FOR CLUTCH AND DISASSEMBLING NUT **mm 34**

PIAGGIO - VESPA - GILERA
APRILIA - 50 2t-4t

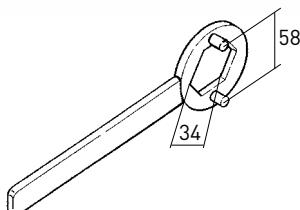

Art. 5442

ATTREZZO BLOCCA PULEGGIA ANTERIORE
 FRONT PULLEY LOCKING TOOL

PER MOTORI / FOR ENGINES
PIAGGIO 250-300cc 4t



PIAGGIO - VESPA - APRILIA - GILERA

Art. 5446

ATTREZZO BLOCCA PULEGGIA ANTERIORE
FRONT PULLEY LOCKING TOOL

PER MOTORI / FOR ENGINES
PIAGGIO 400-500cc 4t



Art. 5445

CHIAVE PER DADO VARIATORE POSTERIORE
REAR VARIATOR NUT WRENCH

PER MOTORI / FOR ENGINES
PIAGGIO 250cc

ES./HEX. mm. 46



Art. 5425

ATTREZZO BLOCCA PULEGGIA ANTERIORE
FRONT PULLEY LOCKING TOOL

PER MOTORI / FOR ENGINES
PIAGGIO 50/125 2t-4t



Art. 5449

CHIAVE PER DADO VARIATORE POSTERIORE
REAR VARIATOR NUT WRENCH

PER MOTORI / FOR ENGINES
PIAGGIO 300cc-500cc

ES./HEX. mm. 55



Art. 5430

ATTREZZO BLOCCA PULEGGIA ANTERIORE
FRONT PULLEY LOCKING TOOL

PER MOTORI / FOR ENGINES
PIAGGIO 125-150cc 4t



Art. 5658

ATTREZZO RITEGNO MOLLA FRIZIONE
CLUTCH SPRING CHECK TOOL

PER MOTORI / FOR ENGINES
PIAGGIO - VESPA

DA / FROM **125cc**
A / TO **500cc 4t**



Art. 5428

ATTREZZO BLOCCA FRIZIONE
CLUTCH LOCKING TOOL

PER MOTORI / FOR ENGINES
PIAGGIO 125-250-300cc 4t



Art. 4802

**CHIAVE PER CANDELE DA 21 mm.
21 mm. MOPEDS SPARK PLUGS SPANNER**

Tubo rinforzato
Reinforced pipe

Conf. / Pack 2 pcs

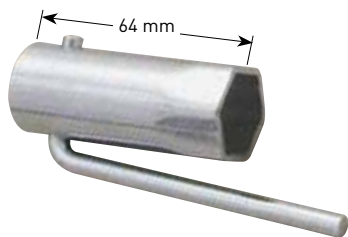

Art. 4804

**CHIAVE PER CANDELE DA 21 mm CON MANICO PIEGATO
21 mm SPARK PLUGS SPANNER WITH FOLDED HANDLE**

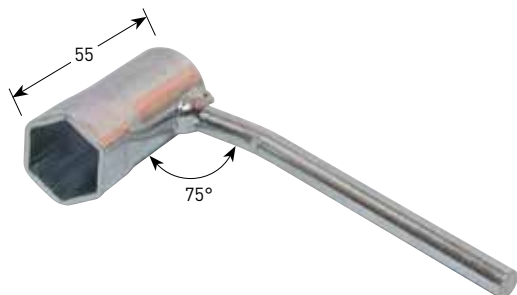

Art. 4807

**CHIAVE PER CANDELE STANDARD DA 21 mm.
21 mm. STANDARD SPARK PLUGS SPANNER**

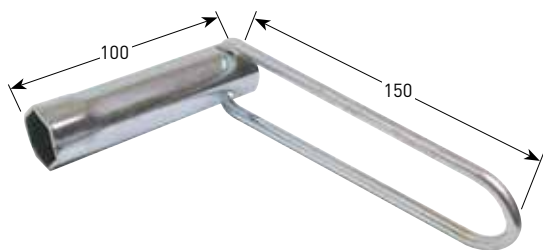

Art. 4835

**SPINA PER CHIAVI CANDELA
PIN FOR SPARK PLUG SPANNERS**

Conf. / Pack 5 pcs

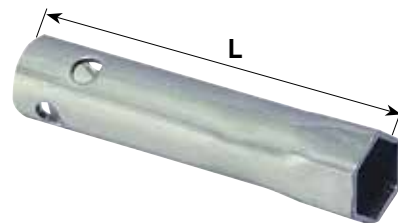
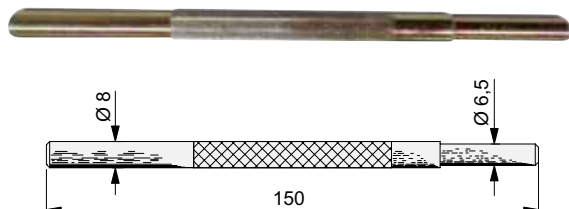

**CHIAVI CANDELA STANDARD
STANDARD SPARK PLUG SPANNERS**

Art. 4810 L= mm 90 Es. - hex. mm. 16

Art. 4811 L= mm 100 Es. - hex. mm. 18

Art. 4812 L= mm 120 Es. - hex. mm. 21

Art. 4814 L= mm 140 Es. - hex. mm. 16

Art. 4818

**CHIAVE CANDELA A DOPPIO ESAGONO
DOUBLE HEXAGON SPARK PLUG SPANNER**

L= mm 120 Es. - hex. mm. 16 - 18

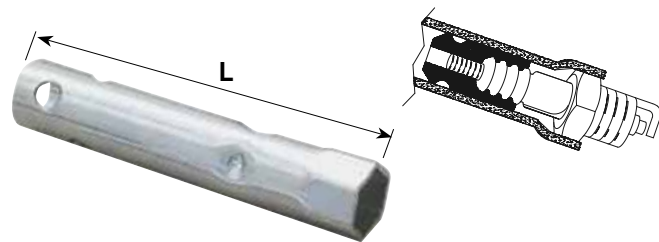
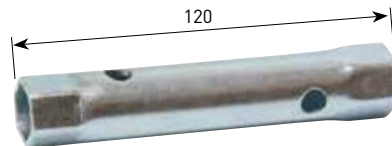

**CHIAVI CANDELA STANDARD CON GOMMINO
STANDARD SPARK PLUG SPANNERS WITH RUBBER**

Art. 4824 L= mm 80 Es. - hex. mm. 16

Art. 4825 L= mm 100 Es. - hex. mm. 16

Art. 4826 L= mm 90 Es. - hex. mm. 13

Art. 4830 L= mm 120 Es. - hex. mm. 18

Art. 4840

NEW

CHIAVE CANDELA A 3 ESAGONI CON MANICO
3 IN 1 SPARK PLUG SPANNER WITH HANDLE

L = mm 75 Es - Hex. mm. 16-18-21

DISPONIBILE DA APRILE 2023
AVAILABLE FROM APRIL 2023



Art. 4863

CHIAVE CANDELA A PIPA
PIPE SPARK PLUG SPANNER

L = mm 46 Es. - hex. mm. 13 x 21



Art. 4842

CHIAVE CANDELA DA 14 mm MOD. HONDA
CON GOMMINO E PUNTALE ESAGONALE
14 mm MOD. HONDA SPARK PLUG SPANNER
WITH RUBBER AND HEXAGONAL PUSH ROD

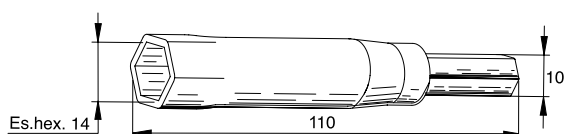

CHIAVI PER CANDELE E RUOTE
SPANNERS FOR PLUG AND WHEEL

Conf. / Pack 2 pcs

Art. 4870

Es. - hex. mm. 11 x 13 x 21
VESPA SPECIAL model
PRIMAVERA - ET3 model

Art. 4874

Es. - hex. mm. 13 x 17 x 21
VESPA SPECIAL model
PRIMAVERA - ET3 model

Art. 4881

Es. - hex. mm. 13 x 11 x 21
VESPA SUPER - SPRINT
PX - PE model

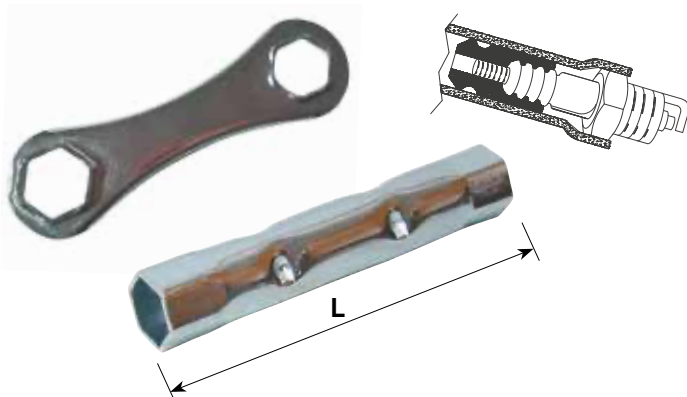

CHIAVI CANDELA A DOPPIO ESAGONO
CON LEVA DI MANOVRA E GOMMINI
DOUBLE HEXAGON SPARK PLUG SPANNERS WITH
WORKING HANDLE AND RUBBERS

Art. 4854

L = mm 120 Es. - hex. mm. 16 - 18

Art. 4856

L = mm 140 Es. - hex. mm. 16 - 18

Art. 4827

CHIAVE CANDELA CON GOMMINO
SPARK PLUG SPANNER WITH RUBBER

L = mm 115 Es. - hex. mm. 16

VESPA PRIMAVERA 125/150 4t 3V

NEW

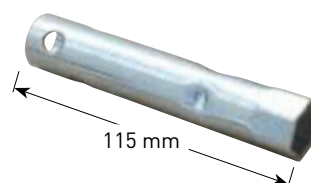

**ATTREZZO PER RIMUOVERE LA BOBINA PORTACANDELA
TOOL TO REMOVE THE SPARK PLUG CONNECTOR**

Art. 5200

PER / FOR
BMW R1100 – R1150
MOTORI / ENGINES **R259**



Art. 5201

PER / FOR
**BMW R1150 - R1200 - F800 -
F650 GS Twin -
K1200 S,R,R-Sport -
K1300 S,R,GT**



Art. 0540

TANICHETTA AUSILIARE DI ALIMENTAZIONE – CAPACITA' 1,5 LT
PER ALIMENTARE IL MOTORE QUANDO E' NECESSARIO RIMUOVERE IL
SERBATOIO.
COMPLETA DI RUBINETTO, CATENELLA, GANCIO, TAPPO E TUBO DI
ALIMENTAZIONE.

AUXILIARY FUEL TANK - CAPACITY 1,5 LT
FOR USE WHEN TUNING A MOTORCYCLE WITH GAS TANK REMOVED.
INCLUDES TAP, HOOK, CHAIN, CAP AND FEEDING PIPE.



Art. 0528

**RUBINETTO IN LINEA PER TUBETTO DA 7 mm
7 mm SMALL FUEL TAP - VALVE BY IN-LINE**

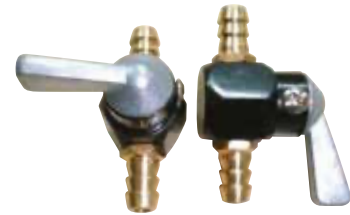

Art. 0530

**FASCETTA STRINGITUBO PER TUBO BENZINA
DA Ø 10mm A 11,5mm
SPESSORE 0,7 mm
HOSE CLAMPS FROM Ø 10mm TO 11,5mm
THICKNESS 0,7 mm**



Conf. / Pack 10 pcs

Art. 0535

**TUBO IN GOMMA 100% NBR
Ø INTERNO 6 mm – LUNGHEZZA 1M
PER BENZINA, GASOLIO, OLIO
COMPLETO DI 2 FASCETTE DI FISSAGGIO
UTILIZZABILE PER NS. ART. 0540
100% NBR RUBBER HOSE
INNER Ø 6 mm – LENGHT 1M
FOR FUEL, GASOLINE, OIL
COMPLETE WITH 2 FIXING CLAMPS
AVAILABLE FOR OUR ART. 0540**

NEW

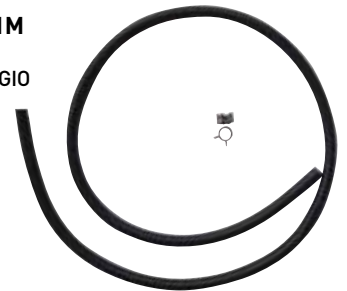

Art. 0543

**VASCHETTA PER RECUPERO OLIO USATO
CON BECCUCCIO SVERSATORE
IN POLIETILENE
DIMENSIONI : 380x212xh73 mm
CAPACITA' : 2 Lt**

**WASTE OIL DRAIN PAN
WITH ANTI-SPLASH LIP
MADE IN POLYETHYLENE
DIMENSIONS : 380x212xh73 mm
CAPACITY : 2 Lt**



Art. 0545

**VASCHETTA MAGNETICA
RETTANGOLARE DA 240X140MM.
CON GOMMA ANTISCIVOLO**

**240X 140MM. RECTANGULAR
MAGNETIC TRAY
WITH SLIP RESISTANT RUBBER**



Art. 0546

**VASCHETTA MAGNETICA
CIRCOLARE Ø 150MM.
CON GOMMA ANTISCIVOLO**

Ø 150MM. **MAGNETIC DISH
WITH SLIP RESISTANT RUBBER**



Art. 0550

**MINI MATERASSINO DA LAVORO
MINI WORKMAT
480 X 320 X 34 MM**



Art. 0616

**LUBRIFICATORE PER CAVI FRENO/FRIZIONE
BRAKE AND CLUTCH CABLE LUBER**

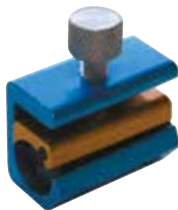

Art. 0620

**MINI OLIATORE TASCABILE
POCKET MINI OILER**



Art. 4943

**SET DI 3 ATTREZZI PER RIMUOVERE GUARNIZIONI, O-RING,
TUBI FLESSIBILI E ALTRO**

**SET OF 3 REMOVER TOOLS FOR SEAL, O-RINGS, FLEXIBLE
HOSES AND OTHER**



Art. 4949

**ATTREZZO SMONTAGGIO/MONTAGGIO MOLLE
SPRINGS DISASSEMBLING/ASSEMBLING TOOL**



Art. 5076

**COPPIA DI GANASCE PER MORSA
PER IL SERRAGGIO DI CORPI TONDI
CAPACITA' DA Ø 26 A Ø 70 MM
CON VITE DI REGOLAZIONE
DELL'ALLINEAMENTO**

**COUPLE OF VICE JAWS
FOR ROUND PARTS LOCKING
CAPACITY FROM Ø 26 TO Ø 70 MM
WITH ALIGNMENT ADJUSTING
SCREW**

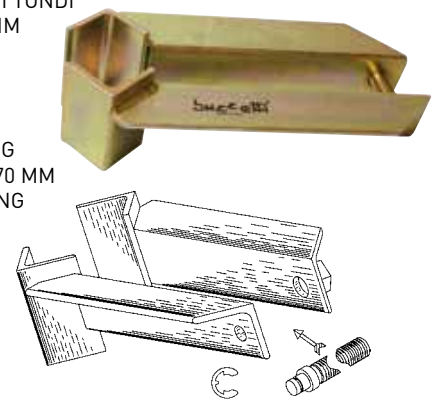

Art. 5078

**COPPIA DI GANASCE DOLCI IN ALLUMINIO PER MORSA
LE DUE MOLLE SERVONO PER L'APERTURA DELLE STESSE**

**COUPLE OF SOFT ALUMINIUM VICE INSERT
THE TWO SPRINGS ALLOW THE TOOL OPENING**



**ATTREZZI RASCHIATORI IN ACCIAIO INOX
SCRAPER TOOLS IN STAINLESS STEEL**

Art. 5082

A = 10 mm.

Art. 5083

A = 15 mm.

Art. 0312

ATTREZZO PER LA REGOLAZIONE DELLA TENSIONE DELLE CINGHIE DENTATE

ISTRUZIONI CON L'ATTREZZO

OUTIL POUR AJUSTER LA TENSION DES COURROIES DENTÉES

MODE D'EMPLOI AVEC L'OUTIL

TENSIONING GAUGE TOOL FOR TIMING BELTS

USER INSTRUCTIONS INCLUDED

PER / FOR **YAMAHA TMAX 530cc**

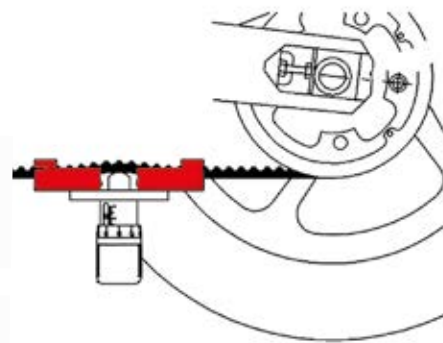
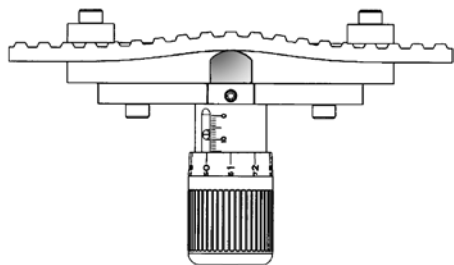

Art. 0568

TESTER PER IL CONTROLLO "DELL'ALTA TENSIONE" DELLA BOBINA

IDEALE NEI MOTORI CON SISTEMA ELETTRONICO

ISTRUZIONI CON IL TESTER

TESTEUR POUR LE CONTRÔLE DE "L'HAUTE TENSION" DE LA BOBINE

IDÉAL DANS LES MOTEURS AVEC SYSTÈME ÉLECTRONIQUE

MODE D'EMPLOI AVEC LE TESTEUR

TESTER TO CHECK THE "HIGH TENSION" OF COIL

IDEAL FOR ELECTRONIC SYSTEM ENGINES

USER INSTRUCTIONS INCLUDED

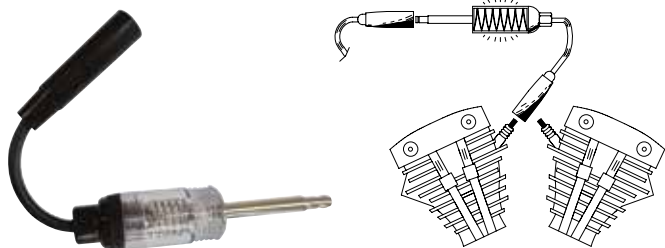

Art. 0572

TESTER PER IL CONTROLLO DELL'EFFICIENZA DELLA CANDELA

CERTIFICATO - CE -

ISTRUZIONI CON IL TESTER.

TESTEUR POUR CONTRÔLER LE BON FONCTIONNEMENT DE BOUGIE

CONFORME - CE -

MODE D'EMPLOI AVEC LE TESTEUR.

TESTER TO CHECK THE SPARK PLUG EFFICIENCY

CERTIFIED - CE -

USER INSTRUCTIONS INCLUDED.



Art. 0570

TESTER PER IL CONTROLLO DELL'EFFICIENZA DELLA BOBINA CON LA SIMULAZIONE DELLA SCINTILLA

ISTRUZIONI CON IL TESTER

TESTEUR POUR CONTRÔLER LA CONDITION DE LA BOBINE PAR LA SIMULATION DE L'ÉTINCELLE

MODE D'EMPLOI AVEC LE TESTEUR

TESTER TO CHECK THE QUALITY OF COIL ACCORDING TO SPARK

USER INSTRUCTIONS INCLUDED

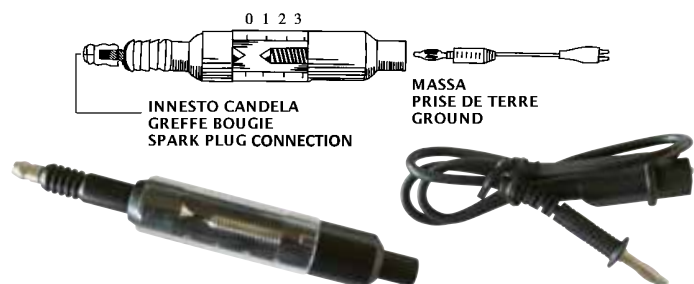

Art. 0576

TESTER PER IL CONTROLLO DELL' H₂O NEL FLUIDO DEI FRENI

INDICA QUANDO E' NECESSARIA LA SOSTITUZIONE DEL FLUIDO.

ISTRUZIONI CON IL TESTER.

TESTEUR POUR CONTRÔLER L'H₂O DANS LE LIQUIDE DES FREINS

INDIQUE QUAND LA VIDANGE EST NÉCESSAIRE.

MODE D'EMPLOI AVEC LE TESTEUR.

BRAKE FLUID TESTER

RAPIDLY INDICATE H₂O CONTENT AND CLEARLY SHOW WHEN BRAKE FLUID MUST BE CHANGED.

USER INSTRUCTIONS INCLUDED.



Art. 5101

TESTER SINCRONIZZATORE CARBURATORI PER MOTORI CON 2 - 3 o 4 CARBURATORI PER IL CONTROLLO DELLA POMPA CARBURANTE E L'ALLINEAMENTO / TARATURA DEI CARBURATORI.

IL KIT CONTIENE MANOMETRI CON MISURAZIONE DA 0 A 76cmHg; TUBI IN GOMMA DA 8x5x950mm; CONNETTORI

DA M5x0.8x169mm;

DA M5x0.8x53mm;

DA M5x0.8x100mm;

DA M6x0.75x53mm;

DA M6x1.0x60mm

E 1 CONNETTORE DA 6x55.

ISTRUZIONI D'USO NELLA CONFEZIONE.

SYNCHRONISATEUR DES CARBURATEURS POUR MOTEURS AVEC 2 - 3 ou 4 CARBURATEURS

POUR LE CONTROLE DE LA POMPE ESSENCE ET L'ALIGNEMENT / ETALONNAGE DES CARBURATEURS. KIT COMPLETE DES MANOMETRES AVEC MESURAGE DE 0 A 76cmHg;

TUBES EN CAOUTCHOUC DE 8x5x950mm; CONNEXEURS DE

M5x0.8x169mm; DE M5x0.8x53mm;

DE M5x0.8x100mm; DE

M6x0.75x53mm; DE M6x1.0x60mm

ET 1 CONNEXEUR DE 6x55.

MODE D'EMPLOI AVEC LE COFFRET.

CARBURETTOR SYNCHRONIZER TESTER FOR ENGINES WITH 2 - 3 or 4 CARBURETTORS

FOR TESTING FUEL PUMP AND CARBURETTORS ALIGNMENT / CALIBRATION.

KIT COMPLETE WITH GAUGES FROM 0 TO 76cmHg MEASURING;

RUBBER HOSES OF 8x5x950mm; CONNECTORS

OF M5x0.8x169mm; OF M5x0.8x53mm; OF M5x0.8x100mm; OF

M6x0.75x53mm; OF M6x1.0x60mm AND 1 CONNECTOR OF 6x55.

USER INSTRUCTIONS INCLUDED.

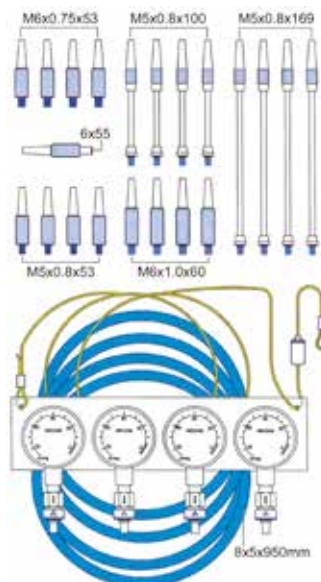

Art. 5116

TESTER SINCRONIZZATORE CARBURATORI PER MOTOCICLI CON 2-3-4 CARBURATORI

PER IL TEST DEL CARBURATORE, POMPA BENZINA E DELLA TRASMISSIONE. CON 4 MANOMETRI LETTURA 1 bar.; 4 TUBI IN GOMMA DA Ø 8xØ 5x 750mm.; 4 TUBI DI ESTENSIONE DA 122mm. E 4 DA 52mm.; 4 CONNETTORI

DA M6x1 - 60mm. DI LUNGHEZZA E 4 CONNETTORI DA M6x0,75 - 53mm. DI LUNGHEZZA; 1 CONO CONNETTORE DA 8x40mm.

ISTRUZIONI D'USO NELLA CONFEZIONE.

SYNCHRONISATEUR DU CARBURATEUR POUR MOTO AVEC 2-3-4 CARBURATEURS

POUR LE CONTROLE DU CARBURATEUR, POMPE ESSENCE ET DE LA TRANSMISSION. AVEC 4 MESUREURS LECTURE 1 bar.; 4 TUBES EN CAOUTCHOUC DE Ø 8xØ 5x 750mm.; 4 TUBES D'EXTENSION DE 122mm. ET 4 DE 52mm.; 4 CONNEXEURS DE M6x1 - 60mm. DE LONGUEUR ET 4 CONNEXEURS DE

M6x0,75 - 53mm. DE LONGUEUR; 1 CONE DE LIASON DE 8x40mm.

MODE D'EMPLOI AVEC LE COFFRET.

ENGINE SYNCHRONIZER TESTER WITH 2-3-4 CARBURETORS

FOR CARBURATOR, FUEL PUMP AND TRANSMISSION TESTING.

WITH 4pcs 1bar. READING GAUGES; RUBBER HOSE 4pcs Ø 8xØ 5x 750mm.;

122mm. AND 52mm. EXTENSION TUBE 4pcs; CONE TYPE CONNECTOR

4pcs M6x1 - 60mm. LENGTH AND 4 pcs M6x0,75 - 53mm. LENGTH; 1pc

8x40mm. CONE TYPE CONNECTOR.

USER INSTRUCTIONS INCLUDED.



Art. 5103

TESTER PER IL CONTROLLO DELLA COMPRESSIONE NEL CILINDRO

CARATTERISTICA: DISPONE DI UNA VALVOLA DI RAPIDO SCARICO DELLA PRESSIONE E DI UN MISURATORE CON CAPACITA' DI 300 PSI. KIT COMPLETO DI MANOMETRO E TRE TUBI CON INNESTO DA 10-12-14 mm. ISTRUZIONI D'USO NELLA CONFEZIONE.

TESTEUR POUR LE CONTRÔLE DE LA COMPRESSION DANS LE CYLINDRE

CARACTERISTIQUE: CE KIT DISPOSE D'UNE SOUPAPE D'ÉCHAPPEMENT RAPIDE DE PRESSION ET D'UNE JAUGE AVEC CAPACITEE DE 300 PSI. KIT COMPLETE DE MANOMETRE, TROIS TUYAUX AVEC ATTAQUE DE 10-12-14 mm. MODE D'EMPLOI AVEC LE COFFRET.

COMPRESSION CYLINDER CONTROL TESTER

FEATURE: EQUIPPED WITH A PRESSURE RELEASE VALVE AND WITH A GAUGE OF 300 PSI CAPACITY. THE PACKAGING INCLUDES: GAUGE, THREE HOSES FOR 10-12-14mm APPLICATIONS.

USER INSTRUCTIONS INCLUDED.



Art. 5117

TESTER PER IL CONTROLLO DELLA PERDITA DI PRESSIONE NEL CILINDRO

UTILE PER UNA RICERCA DI DIFETTI O PERDITE DELLE VALVOLE, DEI PISTONI, DELLE FASCE ELASTICHE E DELLE GUARNIZIONI.

IL MANOMETRO INDICA LA PERDITA SIA IN PERCENTUALE CHE IN PSI. LA COSTANTE IMMISSIONE DI ARIA COMPRESSA PERMETTE DI INDIVIDUARE I DIFETTI ANCHE ATTRAVERSO L'ASCOLTO.

LA CONFEZIONE CONTIENE: UN MANOMETRO, UN TUBO FLESSIBILE CON ATTACCO FILETTATO M14-M18, DUE RIDUZIONI M12-M10 E UN CONNETTORE DI PROLUNGA

ISTRUZIONI D'USO NELLA CONFEZIONE.

TESTEUR POUR LE CONTRÔLE DE LA PERTE DE PRESSION DANS LE CYLINDRE

CE TESTEUR EST UTILE POUR LA RECHERCHE DES DEFAUTS OU DES PERTES DES SOUPAPES, DES PISTONS, DES SEGMENTS DE PISTON ET DES JOINTS.

LA JAUGE INDIQUE LA PERTE EN POURCENTAGE AUSSI QUE EN PSI. LA CONSTANTE INJECTION D'AIR COMPRIME PERMIS EGALEMENT D'IDENTIFIER LES DEFAUTS AUSSI AVEC L'ECOUTE.

L'ENSEMBLE COMPREND : UN MANOMETRE, UN TUYAU AVEC ATTAQUE FILETÉE M14-M18, DEUX REDUCTIONS M12-M10 ET UN CONNECTEUR DE RALLONGE. MODE D'EMPLOI AVEC LE COFFRET.

INSPECTING CYLINDER LEAKDOWN TESTER

THIS TOOL IS USEFUL TO TEST FOR A DIAGNOSES OF FAILED OR LEAKING VALVES, PISTONS, RINGS AND GASKETS. A LARGE GAUGE INDICATES PERCENTAGE OF LEAKING RATHER THAN PSI.

THE CONSTANT SUPPLY OF COMPRESSED AIR ALLOWS FAULTS TO BE PIN-POINTED ALSO BY LISTENING THE LEAKAGE.

THE PACKAGING INCLUDES : A GAUGE, A M14-M18 FLEXIBLE THREADED ADAPTOR, TWO REDUCTIONS M12-M10 AND ONE EXTENSION CONNECTION. USER INSTRUCTIONS INCLUDED.



Art. 5119

POMPA MANUALE PER IL CONTROLLO DELLA DEPRESSIONE CON MANOMETRO MISURATORE

LA POMPA MISURA LA DEPRESSIONE, CREA E MANTIENE IL SOTTOVUOTO. UTILIZZO: VALVOLE CARBURATORE, PRESSIONE DEL LIQUIDO DEI FRENI, POMPA CARBURANTE, VALVOLE MOTORE, REGOLAZIONE DELLA PRESA D'ARIA, INIEZIONE ELETTRONICA.

LA CONFEZIONE INCLUDE ADATTATORI, TUBI, VASCHETTA RACCOGLI-LIQUIDO E ISTRUZIONI D'USO.

POMPE À BRAS POUR LE CONTRÔLE DE LA DEPRESSION AVEC MANOMÈTRE DE MESURE

LA POMPE MESURE LA DEPRESSION, CRÉE ET MAINTIENT LE SOUS VIDE. APPLICATION: SOUPAPES CARBURATEUR, PRESSION LIQUIDE DES FREINS, POMPE À CARBURANT, SOUPAPES MOTEUR, REGULATION PRISE D'AIR, INJECTION ÉLECTRONIQUE.

CONTENU: ADAPTATEURS, TUBES, RÉSERVOIR RACUEILLE-LIQUIDE ET MODE D'EMPLOI.

HAND VACUUM PUMP KIT TO CHECK DEPRESSION WITH MEASURING GAUGE

THE PUMP MEASURES THE DEPRESSION CREATES AND HOLDS VACUUM. APPLICATION: CARBURETOR VALVES, BRAKE FLUID PRESSURE, FUEL PUMP, ENGINE VALVES, AIR INTAKE CONTROL, ELECTRONIC INJECTION. PACKING CONTENTS ADAPTORS, HOSES, RESERVOIR FOR BRAKE BLEEDING & FLUID. USER INSTRUCTIONS INCLUDED.



Art. 5111

ATTREZZO PER FILTRO. TIPO CON BANDA IN NYLON.
CAPACITA' MAX FINO A 120mm
STRAP TYPE OIL FILTER WRENCH. CAPACITY UP TO 120mm MAX



**ATTREZZO PER LO SMONTAGGIO DEI FILTRI OLIO MOTORE -
INNESTO QUADRO**
OIL FILTER TOOL - SQUARE CLUTCH

Art. 5180

PER FILTRI DA Ø 65 A 67 - 14 ANGOLI
FOR FILTERS Ø 65 TO 67 - 14 FLUTES

Art. 5181

PER FILTRI Ø 68 CON 14 ANGOLI
FOR FILTERS Ø 68 WITH 14 FLUTES

Art. 5182

PER FILTRI Ø 73 CON 14 ANGOLI
FOR FILTERS Ø 73 WITH 14 FLUTES

Art. 5183

PER FILTRI Ø 74 CON 15 ANGOLI
FOR FILTERS Ø 74 WITH 15 FLUTES

Art. 5185

PER FILTRI DA Ø 74 A 76 CON 15 ANGOLI
FOR FILTERS Ø 74 TO 76 WITH 15 FLUTES

Art. 5186

PER FILTRI Ø 76 CON 14 ANGOLI
FOR FILTERS Ø 76 WITH 14 FLUTES
VALIDO PER / VALID FOR BMW

Art. 5188

PER FILTRI DA Ø 75 A 77 CON 15 ANGOLI
FOR FILTERS Ø 75 TO 77 WITH 15 FLUTES

Art. 5197

PER / FOR **BMW**
ANCHE PER / ALSO FOR **GUZZI - PIAGGIO**
PER FILTRI Ø 76 CON 12 INNESTI RIGATI
FOR FILTERS Ø 76 WITH 12 SCORED CLUTCHES

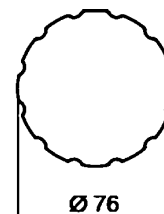

ATTREZZO PER FILTRI OLIO CON BANDA DI GRIPPAGGIO IN ACCIAIO
OIL FILTERS TOOL WITH SEIZING STEEL DEVICE

Art. 5167

DA/FROM Ø 71 A/TO 79 mm

Art. 5168

DA/FROM Ø 87 A/TO 95 mm

Art. 5175

**ATTREZZO A GRIPPAGGIO MECCANICO REGOLABILE PER
FILTRI OLIO DA Ø 61 A 97 MM**
**MECHANICAL ADJUSTABLE SEIZING TOOL FOR OIL FILTER
FROM Ø 61 TO 97 MM**



Art. 5106

SCOOTER APRILIA - MALAGUTI - PEUGEOT - PIAGGIO - GILERA - VESPA

ATTREZZO PER FILTRO MOTORI PIAGGIO 300-400-500cc 4t. A DOPPIO USO, PER CARTUCCE POLIGONALI E A INNESTI RIGATI

PIAGGIO 300-400-500cc 4s ENGINES FILTER TOOL WITH DOUBLE USE, FOR SCORED CLUTCHES AND POLYGONAL CARTRIDGES

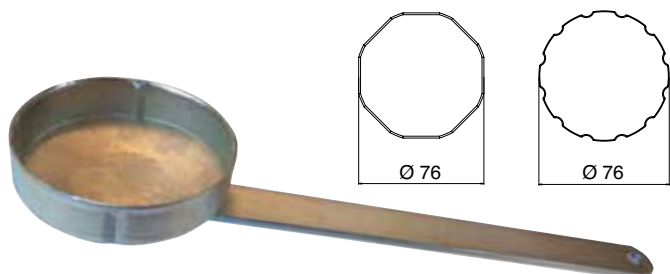

Art. 1082

ROBUSTO ATTREZZO COMPRIMI MOLLA AMMORTIZZATORE CON 4 ADATTATORI DA Ø 60-66-72-75 mm

HEAVY-DUTY SHOCK ABSORBER SPRING COMPRESSOR TOOL WITH 4 ADAPTERS OF Ø 60-66-72-75 mm



Art. 5110

ATTREZZO SMONTA FILTRO OLIO PER SCOOTER da 125 a 300 cc. 4t CARTUCCIA FILTRO DI Ø 49 mm CON 14 INNESTI

OIL FILTER DISASSEMBLING TOOL FOR SCOOTER from 125 to 300 cc 4s Ø 49 mm - 14 FLUTES FILTER CARTRIDGES



Art. 1090

ATTREZZO COMPRIMI MOLLA AMMORTIZZATORE POSTERIORE PER SCOOTER E MINIMOTO

REAR COIL SPRING COMPRESSOR FOR SCOOTER AND MINIBIKE



Art. 5112

SCOOTER APRILIA - MALAGUTI - PEUGEOT - PIAGGIO-GILERA - VESPA

ATTREZZO PER FILTRO MOTORI PIAGGIO da 125 a 250 cc.

PIAGGIO ENGINES FROM 125 TO 250 cc. FILTER TOOL

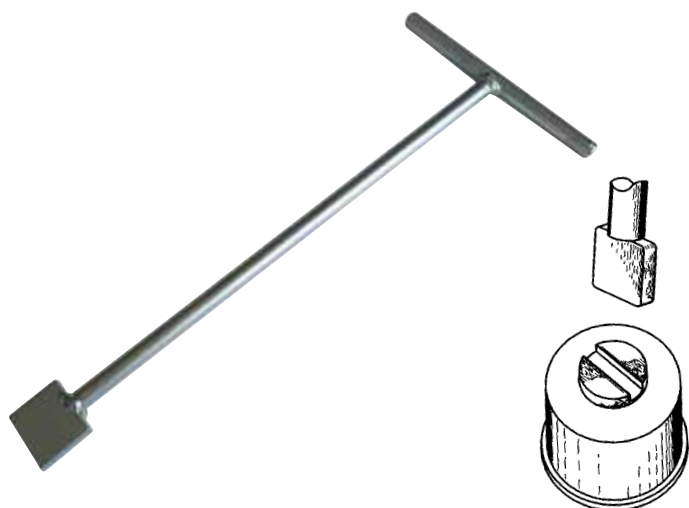

Art. 5048

PINZA PER ANELLI SEEGER INTERNI CON BECCUCCI A 90° PER FORI PROFONDI

INTERNAL CIRCLIP PLIERS WITH 90° LONG TIP FOR DEEP HOLE AREA



Art. 5049

**PINZA COMPONIBILE PER SEEGER INTERNI E ESTERNI
COMPLETA DI 4 PUNTALI**

**COMBINATION INTERNAL/EXTERNAL CIRCLIP PLIER SET
COMPLETE WITH 4 JAWS**

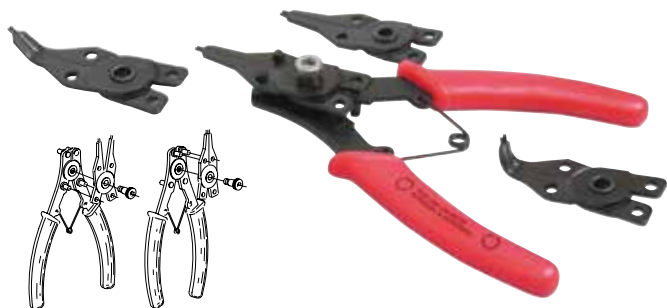

INTERNAL EXTERNAL

Art. 5414

**SET DI 2 PINZE IN NYLON
PER TUBI BENZINA**

**FUEL HOSES CLAMP - 2 pcs
NYLON PLIER SET**



Art. 5089

**LAPPATORE OSCILLANTE / ROTANTE PER SMERIGLIATURA SEDI VALVOLA
SEDI VALVOLE IN CATTIVA CONDIZIONE LIMITANO LA PERFORMANCE DEL
MOTORE.**

MINORE POTENZA, DIFFICOLTA' NELL'AVVIAMENTO (STARTING) E PERDITE DI GAS SONO IL SINTOMO DEL DANNEGGIAMENTO DELLE SEDI VALVOLA.

L'ATTREZZO E' PROVVISORIO DI **DUE LAPPATORI DA 19mm E 23mm.** SI UTILIZZA CON UN TRAPANO ELETTRICO PORTATILE.

OSCILLATING / ROTATING VALVE GRINDING TOOL FOR GOOD MAIN TENANCE OF VALVE SEATS

BADLY SEATED VALVES REDUCE ENGINE PERFORMANCE. LOSS OF POWER, POOR STARTING, GAS ESCAPING ARE SYMPTOM OF SEATED VALVES DAMAGE.

THE TOOL IS EQUIPPED WITH **TWO SUCKER HEADS OF 19 AND 23mm.**

USABLE WITH A PORTABLE ELECTRIC DRILL



Art. 5088

**COPPIA LAPPATORI DI RICAMBIO DA 19
mm E 23 mm PER ART. 5089**

**COUPLE OF 19 / 23 mm SPARE PARTS
SUCKER HEADS FOR ART. 5089**



Art. 5090

**COPPIA ATTREZZI PER LAPPATURA SEDI VALVOLA
DI Ø 16, 21, 25, 28 MM IN NEOPRENE**

**COUPLE OF VALVE LAPPERS TOOL
Ø 16, 21, 25, 28 MM -IN NEOPRENE**



Art. 4910

**CACCIAVITE A PUNTA PIATTA ARROTONDATA
LUNGHEZZA 90 mm**

**SCREWDRIVER WITH ROUND SLOTTED HEAD
90 mm LENGHT**

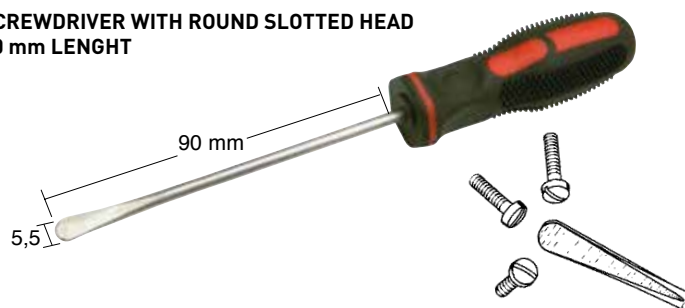

Art. 4916

**CACCIAVITE EXTRALUNGO A PUNTA PIATTA DI 4 mm
LUNGHEZZA 300 mm**

**EXTRA LONG SCREWDRIVER WITH 4 mm SLOTTED HEAD
300 mm LENGHT**

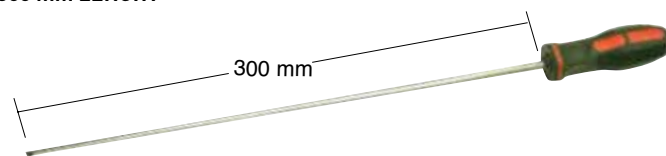

Art. 4919

**CACCIAVITE PER LA REGOLAZIONE DEI CARBURATORI CON TESTA VITE
A "D" DI 4,1 mm**

4,1 mm D-TYPE SOCKET DRIVER FOR CARBURETTORS ADJUSTMENT

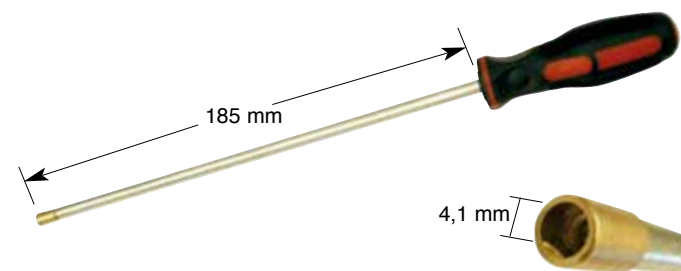

CACCIAVITI A PERCUSSIONE CON TORSIONE DESTRA O SINISTRA - UTILI PER SBLOCCARE VITI OSSIDATE E PER UN FORTE SERRAGGIO

IMPACT SCREWDRIVERS WITH RIGHT OR LEFT DRIVING DIRECTION - USEFUL FOR LOOSENING RUSTED SCREWS AND HEAVY-LOCKING

Art. 4917

CACCIAVITE MANUALE A PERCUSSIONE

PER VITI CON TESTA A CROCE; LINEARE; ESAGONALE DA 6 E 8 mm.

IMPACT SCREWDRIVER

FOR CROSS HEAD SCREWS; SLOTTED; AND 6 - 8 mm HEXAGON.

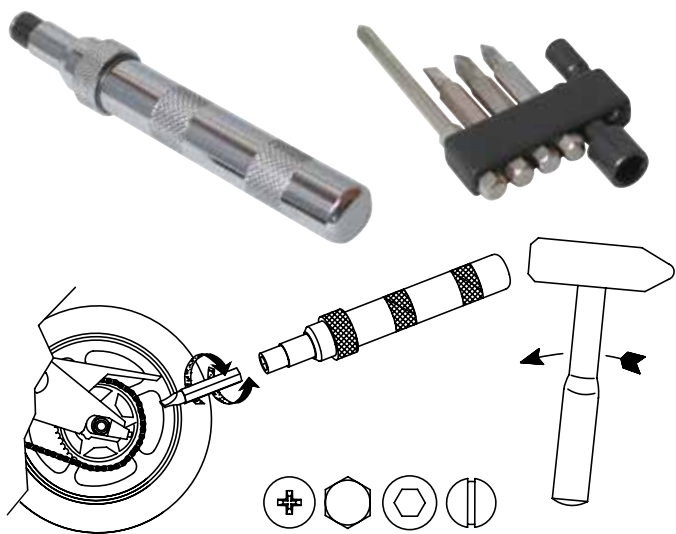

Art. 4918

CACCIAVITE MANUALE A PERCUSSIONE - TOP QUALITY

CON PUNTE ESAGONALI DA 4 - 5 - 6 - 8mm

PUNTE TORX® DA T-40 T-45

PUNTE CRUCIFORMI PH 1 - 2 - 3

PUNTA CACCIAVITE DA 8

PUNTE CRUCIFORMI PH 2-3, LUNGHEZZA 80mm

IN ELEGANTE ASTUCCIO DI METALLO

TOP QUALITY - IMPACT SCREWDRIVER

CONTENTS :

HEX BITS 4 - 5 - 6 - 8mm

TORX® BITS T-40 T-45

CROSS HEAD BITS PH 1 - 2 - 3

FLAT BIT 8 mm

CROSS HEAD BITS PH 2-3 80mm LENGHT

PACKING: ELEGANT METAL BOX



Art. 5118

CALIBRO PER CARBURATORI

PER MISURARE IL LIVELLO DEL GALLEGGIANTE, IL CONTROLLO DELLA SUPERFICIE DELLE GUARNIZIONI DEL GALLEGGIANTE E DEL CARBURATORE

CARBURETOR'S GAUGE

USEFUL TO GAUGE THE FLOAT LEVEL, TO CHECK THE GASKET FLOAT AND CARBURETOR'S SURFACE



Art. 5115

KIT PER RIPARAZIONE CARBURATORI CON TESTA DI ROTAZIONE A 90°, COMPLETO DI 7 ATTREZZI

CARBURETOR ADJUSTING SET WITH 90° ROTATION HEAD, COMPLETE OF 7 TOOLS



Art. 5113

ATTREZZO REGOLAZIONE VITI SUL CARBURATORE

LUNGHEZZA TESTA 25mm PIEGATA A 110°

LUNGHEZZA TOTALE 430mm - CACCIAVITE ROTANTE

ADJUSTING TOOL FOR CARBURETOR SCREWS

HEAD LENGHT 25mm, 110° ANGLED

TOTAL LENGHT 430mm - ROTATING SCREWDRIVER



Art. 0586

ATTREZZO PER MISURARE E PULIRE GLI UGELLI DEI CARBURATORI

CON 20 MISURATORI DA 0,45 A 1,5 mm

CARBURETORS NOZZLE MEASURING AND CLEANING TOOL SET

WITH 20 SIZES FROM 0,45 TO 1,5 mm



Art. 4913

SET DI PUNTE CONICHE PER SVITARE VITI CON TESTA DANNEGGIATA
8 PZ DA 3mm A 12mm

LA CARATTERISTICA DELLA PUNTA E' DI ESSERE AUTOGRIPPANTE
NON USARE AVITATORI AD ARIA
IL PARTICOLARE E' PROTETTO DA BREVETTO

SET OF CONICAL POINTS TO REMOVE DAMAGED HEAD SCREWS

8 PCS FROM 3mm TO 12mm
SELFSEIZING POINT - DON'T USE AIR SCREWDRIVER
TOOL PATENTED



Art. 5418

SET DI CHIAVI SNODATE PER GHIERE A SETTORE IN ACCIAIO AL CROMO VANADIO CON NASELLO TONDO Ø 4 - Ø 5 - Ø 6 - Ø 7,9 mm E NASELLO QUADRO DI 5 - 10 - 12 mm
CAPACITÀ: Ø 35/60 - Ø 60/90 - Ø 90/120 mm

ADJUSTABLE WRENCHES SET FOR RING SECTORS IN CHROME VANADIUM STEEL WITH ROUND PIN Ø 4 - Ø 5 - Ø 6 - Ø 7,9 mm AND SQUARE PIN OF 5 - 10 - 12 mm
CAPACITY: Ø 35/60 - Ø 60/90 - Ø 90/120 mm

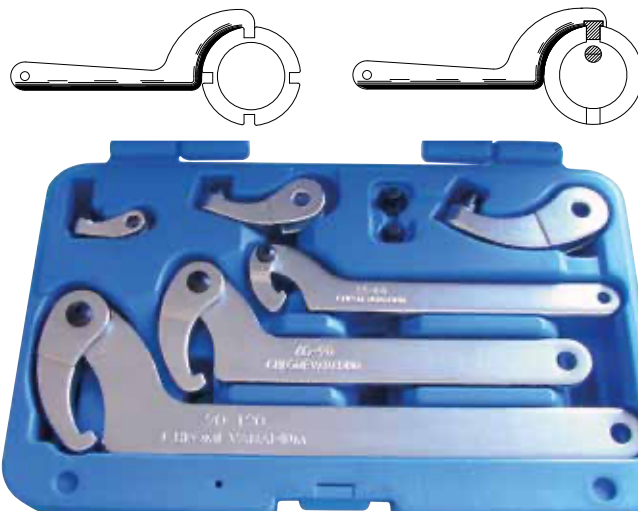

Art. 5140

NEW

ATTORCIGLIATRICE PER FILO DI SICUREZZA
LUNGHEZZA MM. 215

IL FILO ATTORCICLIATO SI MODELLA CON FACILITA' E SENZA DANNI CON LA STESSA PINZA.
UTILE PER EVITARE LO SVITAMENTO DI DADI E BULLONI.

SAFETY WIRE TWISTER PLIER

LENGHT MM. 215

THE TWISTED WIRE IS EASY TO MOULD WITHOUT DAMAGE WITH THE SAME PLIER.
DESIGNED TO PREVENT NUTS/BOLTS FROM GETTING UNFASTED.

DISPONIBILE DA APRILE 2023

AVAILABLE FROM APRIL 2023



Art. 0600

INSTALLATORI PER PRIGIONIERI

SET DI 3 PEZZI DA M6x1 - M8x1,25 - M10x1,25

STUD INSTALLATION TOOLS

SET OF 3 PIECES SIZE M6x1 - M8x1,25 - M10x1,25



Art. 0605

NEW

SET DI ATTREZZI PER SMONTARE E RIMONTARE I PRIGIONIERI

CON INNESTI M6 - M8 - M10 - M12
E CHIAVE A CRICCHETTO MM. 14 x 17

STUD REMOVER & INSTALLER SET

WITH 4 PCS SIZE M6 - M8 - M10 - M12
AND GEAR WRENCH MM. 14 x 17



Art. 5415

CHIAVE REGOLABILE PER GHIERE A SETTORE
CAPACITÀ DA Ø 25 mm A Ø 70 mm

ADJUSTABLE LOCKING RING SECTOR
TOOL FROM Ø 25 mm TO Ø 70 mm

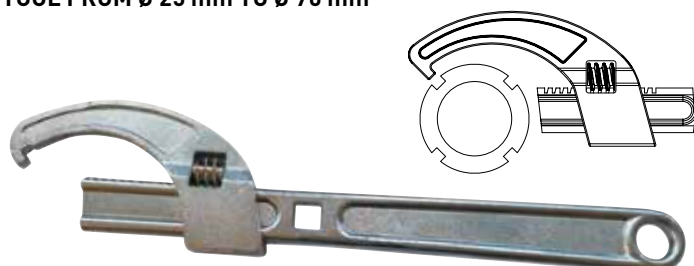

Art. 5099

ATTREZZO UNIVERSALE COMPRIMI MOLLE - VALVOLE
CON 5 ADATTATORI DA 16 - 19 - 23 - 25 - 30 MM, 3 VITI DI
COMPRESSIONE DA 50-90-110 MM DI LUNGHEZZA

UNIVERSAL VALVE SPRING COMPRESSOR TOOL
WITH 5 COLLECT ADAPTORS 16 - 19 - 23 - 25 - 30 MM, 3
COMPRESSOR'S SCREWS OF 50-90-110 MM LENGHT



Max. Opening: 175mm Max. Depth: 125mm

Art. 5100

ATTREZZO UNIVERSALE (MAXI) COMPRIMI MOLLE - VALVOLE
CON 5 ADATTATORI DA 16, 19, 23, 25, 30 MM, 3 VITI DI COMPRESSIONE
DA 60, 100, 100 MM DI LUNGHEZZA

(MAXI) UNIVERSAL VALVE SPRING COMPRESSOR TOOL
WITH 5 COLLECT ADAPTORS 16, 19, 23, 25, 30 mm, 3 COMPRESSOR'S
SCREWS OF 60, 100, 100 mm LENGHT



Max. Opening: 230mm Max. Depth: 130mm

Art. 5662

**ATTREZZO PER METTERE IN CARICA LA
MOLLA DEL SETTORE AVVIAMENTO**
**TOOL TO REASSEMBLE THE START SHAFT
SPRING**
PER / FOR KYMCO-PEUGEOT
TUTTI I MODELLI 2t-4t DA 50 A 125
ALL MODELS 2s-4s FROM 50 TO 125



Art. 5670

**ATTREZZO PER METTERE IN CARICA LA
MOLLA DEL SETTORE AVVIAMENTO**
**TOOL TO REASSEMBLE THE START SHAFT
SPRING**

PER MOTORI / FOR ENGINES
PEUGEOT TWEET 50/125/150
SYM 125/150 4t - SYMPHONY
E ALTRI / AND OTHERS



Art. 5040

ATTREZZO COMPRESSIONE FASCE ELASTICHE
PER PISTONI Ø DA 40 A 80 mm

SMALL ENGINE PISTON RING COMPRESSOR
FOR PISTONS FROM Ø 40 TO 80 mm



Art. 5042

PINZA PER TOGLIERE L'ANELLO DI TENUTA DELLO SPINOTTO DEL PISTONE
CON UN BECCO DENTELLATO E UN BECCO A PUNTA SCANALATA

PISTON RING REMOVER PLIER
WITH CROSSED AND GROOVED HEAD

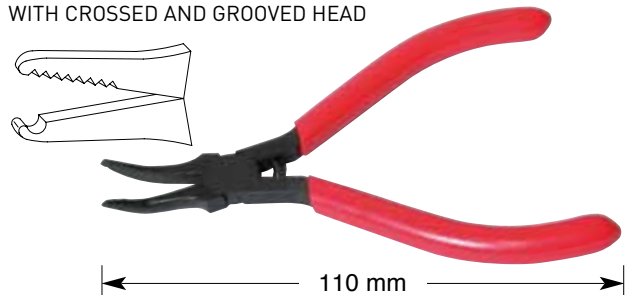

Art. 5044

**ATTREZZO PER FACILITARE L'INSERIMENTO DEL PISTONE NEL
CILINDRO SERRANDO LE FASCE ELASTICHE**
CAPACITA' DA Ø 40 A 85 mm

**PISTON RING TOOL IT MAKES EASIER THE INSTALLATION OF PISTON
INTO CYLINDER WITH PISTON RINGS COMPRESSION**
CAPACITY FROM Ø 40 TO 85 mm



Art. 5045

ATTREZZO ESPANSORE FASCE ELASTICHE PISTONI
ANELLI CON SPESSORE DA 1,2 A 6,3 mm

PISTON RING EXPANDER TOOL
RING WIDTHS FROM 1,2 TO 6,3 mm

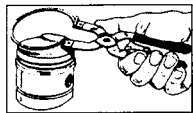

Art. 5060

ATTREZZO MONTAGGIO/SMONTAGGIO SPINOTTO PISTONE
PISTONE Ø 13, 15, 16, 19, 22 mm

PISTON SPINDLE ASSEMBLING/DISASSEMBLING TOOL
TOOL Ø 13, 15, 16, 19, 22 mm



ATTREZZO BLOCCA PISTONE
PISTON LOCKING TOOL

Conf. / Pack 1 pc

Art. 4931

PER CANDELE / FOR SPARK PLUGS
DA / FROM 14

Art. 4932

PER CANDELE / FOR SPARK PLUGS
DA / FROM 12

Art. 4936

M= 14 x 1,25

MICROMETRO PER LA MESSA A PUNTO DEL MOTORE
ISTRUZIONI NELLA CONFEZIONE
ENGINE **MICROMETER** TIMING TOOL
USER INSTRUCTION INCLUDED

Conf. / Pack 1 pc

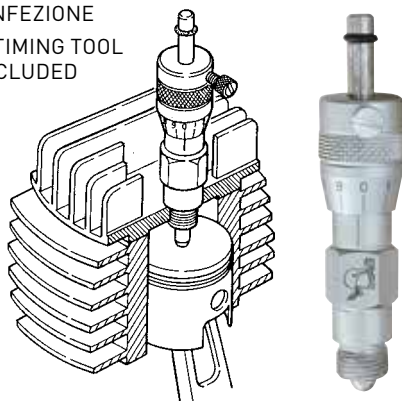

Art. 0594

GONIOMETRO ANGOLARE

MISURA L'ANGOLO DI TORSIONE PER UN SERRAGGIO
ALLINEATO DI DADI, VITI E BULLONI
FOGLIO ISTRUZIONI NELLA CONFEZIONE

ANGULAR TORQUE GAUGE

ALLOWS OPERATOR TO ACCURATELY TIGHTEN NUTS,
SCREWS AND BOLTS
USER INSTRUCTIONS INCLUDED



Art. 5121

ATTREZZO REGOLAZIONE PUNTERIE MOTORI 4t

SET COMPLETO DI 3 CHIAVI CON ESAGONO DA 8 - 9 - 10 mm CON MANICO;
REGOLATORI CON INNESTO QUADRO DI 3 E 4 mm E INNESTO A TAGLIO

4s ENGINES TAPPET ADJUSTING TOOL SET

SET CONTAINS 3 HEXAGONAL WRENCHES OF 8 - 9 - 10 mm WITH HANDLE;
ADJUSTERS WITH SQUARE JOINT OF 3 AND 4 mm AND SLOT JOINT



Art. 5120

ATTREZZO REGOLAZIONE PUNTERIE PER MOTORE 4t CON 3
GUIDE ESAGONALI DI 8 - 9 - 10 mm

TAPPET ADJUST TOOL FOR 4s ENGINE WITH 3 HEXAGONAL
GUIDES 8 - 9 - 10 mm



Art. 5122

ATTREZZO UNIVERSALE SMONTAGGIO
CHIAVELLE DELLE VALVOLE

PER MOTORE SCOOTER 4t

VALVE COTTER UNIVERSAL TOOL
FOR SCOOTER 4s ENGINE



Art. 5035

ATTREZZO PROFESSIONALE SMONTA CARTER MOTORE
PER MOLTI TIPI DI MONOCILINDRICI VERTICALI A 2 E 4 TEMPI
CON 3 + 3 VITI DA 6 & 8 mm x 200

PROFESSIONAL CRANKCASE SEPARATOR TOOL
FOR MOST 2 & 4 STROKE ENGINES WITH VERTICALLY SINGLE CYLINDERS
EQUIPPED WITH 3 + 3 BOLTS OF 6 & 8 mm x 200



Art. 5038

ATTREZZO UNIVERSALE PER SMONTARE IL SEMICARTER DEL MOTORE
DA 50 A 250cc.

CRANK BOX TOOL TO DISASSEMBLE THE ENGINE HALF CARTER FROM
50 TO 250cc.



Art. 5036

ATTREZZO PER IL MONTAGGIO DELL'ALBERO MOTORE NEL SEMICARTER
COMPLETO DI 2 INNESTI FILETTATI DA M10 x 1.25 E M12 x P1.25

CRANK INSTALL TOOL FOR THE CRANKSHAFT ASSEMBLY INTO THE
HALF CARTER
EQUIPPED WITH 2 M10 x 1.25 AND M12 x P 1.25 THREADED JOINTS



Art. 5037

ATTREZZO PROFESSIONALE PER SMONTARE IL SEMICARTER DEL MOTORE
COMPLETO DI 3 VITI DA M8 E 3 PROLUNGHE DA M6
CAPACITA' DI UTILIZZO DA 22 A 120 MM DALLA VITE CENTRALE.
AMPIA GAMMA DI UTILIZZO

HEAVY-DUTY CRANK CASE SEPARATOR TOOL
EQUIPPED WITH 3 M8 SCREWS AND 3 M6 EXTENSIONS
USER CAPACITY FROM 22 TO 120 MM FROM THE CENTRE SCREW.
WIDE RANGE OF USE



Art. 5151

SET GUIDA CUSCINETTI E BOCCOLE

UTILE PER RIMETTERLI CORRETTAMENTE NELLE LORO SEDI
CON 6 GUIDE IN ALLUMINIO DA \varnothing 40 mm. A 65 mm.

BUSHING/BEARINGS DRIVER SET

USEFUL TO PLACE THEM CORRECTLY INTO THEIR SEATS
WITH 6 ALUMINIUM SLIDES FROM \varnothing 40 mm. TO 65 mm.



Art. 5030

SERIE ESTRATTORI PER CUSCINETTI CARTER MOTORE completa di asta con battente. Estrattori per interno motore da \varnothing 8, 10, 12, 15, 17, 20, 25, 30 mm e per silent-block da 20x17, 30x28 mm

ENGINE CARTER BEARINGS PULLER TOOL complete with sliding sledgehammer. Inner engine puller from \varnothing 8, 10, 12, 15, 17, 20, 25, 30 mm and for silent-block from 20x17, 30x28 mm



ESTRATTORI DI RICAMBIO PER ART. 5030
SPARE PARTS PULLERS FOR ART.5030

Art. 5000 \varnothing 8 mm

Art. 5009 \varnothing 17 mm

Art. 5002 \varnothing 10 mm

Art. 5012 \varnothing 20 mm

Art. 5004 \varnothing 12 mm

Art. 5017 \varnothing 25 mm

Art. 5007 \varnothing 15 mm

Art. 5022 \varnothing 30 mm



ESTRATTORI DI RICAMBIO PER ART. 5030 PER SILENT-BLOCK
SPARE PARTS PULLERS FOR ART.5030 FOR SILENT-BLOCK

Art. 5024 20 x 17 mm

Art. 5027 30 x 28 mm

Art. 5028

SET DI 6 ATTREZZI PER SMONTARE E RIMONTARE I CUSCINETTI DELLE RUOTE
CON ESPANSORI \varnothing 10 - 12 - 15 - 17 - 20 - 25 mm

6 pcs WHEEL BEARING REMOVER AND INSTALLER SET
WITH 10 - 12 - 15 - 17 - 20 - 25 mm COLLETS



Art. 5032

SERIE DI ESTRATTORI PER CUSCINETTI NEL CARTER

Capacità 8-25 mm (7 attrezzi leva cuscinetto).
Regolazione larghezza zampe da 26 a 66 mm

BLIND HOLE BEARINGS PULLER SET
Capacity 8-25 mm (7 bearing puller tools).
Width leg capacity from 26 to 66 mm

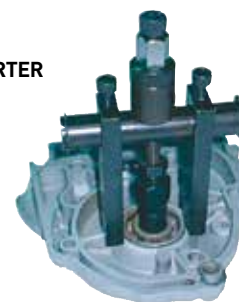

Art. 5068

ATTREZZO PER LO SMONTAGGIO DEL CUSCINETTO SULL'ALBERO MOTORE PARTICOLARMENTE ADATTO QUANDO IL CUSCINETTO E' ADERENTE ALLA FIANCATA COME SUI MOTORI PIAGGIO
CAPACITA' DA Ø 28 A Ø 75 mm
LA FINITURA DELL'ATTREZZO E' CROMATA E I 2 GUSCI SONO IN ACCIAIO DI ALTA QUALITA'
CONFEZIONATO IN ASTUCCIO DI METALLO

CRANK BEARING PULLER TOOL PARTICULARLY SUITABLE WHEN THE BEARING IS STICKING TO THE SIDE AS FOR PIAGGIO ENGINES
CAPACITY FROM Ø 28 TO Ø 75 mm
TOOL CHROME FINISHED AND 2 SHELLS IN HIGH QUALITY STEEL - SUPPLIED IN METAL BOX

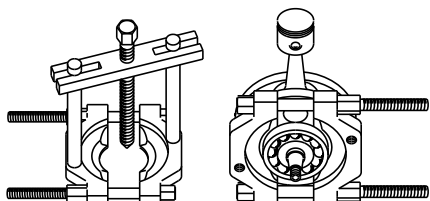

Art. 5070

ATTREZZO SMONTAGGIO CUSCINETTO ALBERO MOTORE
CON GUSCI PER CUSINETTI DA Ø 30 A Ø 50mm
E GUSCI PER CUSINETTI DA Ø 50 A Ø 75mm
BRACCI DA 60mm A 190mm

UNIVERSAL CRANK BEARINGS PULLER TOOL
WITH SHELLS FOR BEARINGS FROM Ø 30 TO Ø 50mm AND SHELLS FOR BEARINGS FROM Ø 50 TO Ø 75mm
ARMS FROM 60mm TO 190mm



Art. 5033

ESTRATTORE A 3 GRIFFE PER TOGLIERE I CUSCINETTI FACENDO PRESA SULL'ANELLO INTERNO

CAPACITA':
DA Ø INTERNO 13mm
A Ø 38mm

3 JAWS PILOT BEARINGS PULLER TOOL TO GRASP THE INTERNAL RING

CAPACITY:
FROM INTERNAL Ø 13mm
TO Ø 38mm

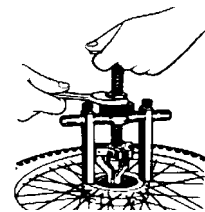

Art. 5034

ESTRATTORE PER INGRANAGGI E CUSCINETTI DI PICCOLO DIAMETRO (DA 19 A 45 mm)

MICRO GEAR AND BEARING PULLER TOOL (SPREAD FROM 19 TO 45 mm)



Art. 5058

ATTREZZO PER TOGLIERE GLI ANELLI DEI CUSCINETTI DAL CANNOTTO DELLO STERZO

CAPACITA' DA Ø 30mm A 68mm
INSERIRE L'ATTREZZO NEL CANNOTTO E ALLARGARE I DUE BRACCI CON LA VITE. DAL LATO OPPOSTO, USANDO UNO SPEZZONE DI LEGNO O ALLUMINIO, BATTERE PER ESPELLERE IL CUSCINETTO.

STEERING STEM BEARING REMOVAL TOOL

CAPACITY FROM Ø 30mm TO 68mm
INSERT IT INTO THE STEM AND OPEN THE TWO ARMS WITH THE SCREW. ON THE OTHER SIDE, USING A WOODEN OR ALUMINIUM BAR PUT THE BEARING THROUGH.

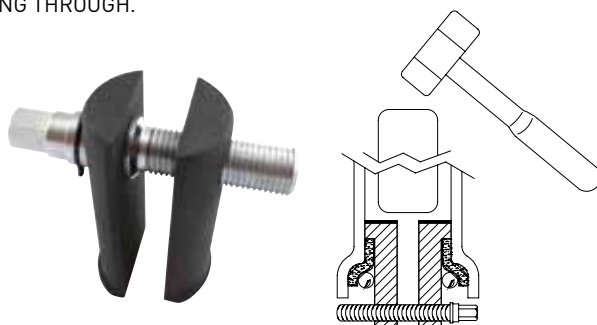

Art. 5054

ATTREZZO PIANTAGGIO CUSCINETTI CONICI SUL PIANTONE
IL TUBO DI GUIDA E' COMPLETO DI 3 RIDUZIONI PER CUSCINETTI DI Ø INTERNO 25/26/28/29/30 (1", 1-1/8" E 1-3/8")

STEERING TUBE BEARING INSTALLER ON THE FORK HEAD
THE GUIDE TUBE IS EQUIPPED WITH 3 BEARINGS REDUCTIONS OF INTERNAL Ø 25/26/28/29/30 (1", 1-1/8" AND 1-3/8")

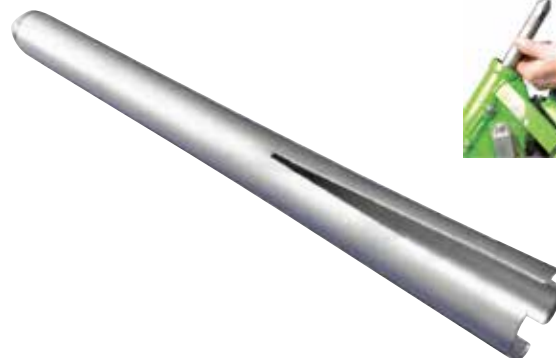

ATTREZZI CON TERMINALE A ESPANSIONE PER ESTRARRE LE CALOTTE DAL TUBO DI STERZO

IN ACCIAIO Cr-Mo

TOOLS WITH EXPANSION END TO TAKE OUT THE BEARING CUPS FROM THE STEERING TUBE

IN Cr-Mo STEEL

Art. 5051

CAPACITA' DA Ø 26mm A Ø 35mm
CAPACITY FROM Ø 26mm TO Ø 35mm

Art. 5053

CAPACITA' DA Ø 35mm A Ø 55mm
CAPACITY FROM Ø 35mm TO Ø 55mm

ATTREZZI PER BLOCCARE LA ROTAZIONE DELLA PULEGGIA ANTERIORE FRONT PULLEY LOCKING TOOL - PREVENT PULLEY ROTATION



Art. 5425

PER MOTORI / FOR ENGINES
PIAGGIO 50/125 cc 2t-4t



Art. 5430

PER MOTORI / FOR ENGINES
PIAGGIO 125-150cc 4t

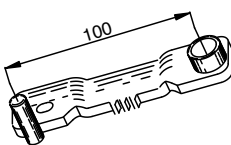
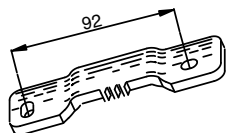

Art. 5458

PER MOTORI / FOR ENGINES
PEUGEOT KISBEE 50cc 4t
CON DISTANZIALE E BULLONCINO
WITH SPACER AND SMALL BOLT

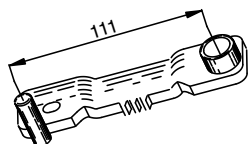

Art. 5468

PER MOTORI / FOR ENGINES
PEUGEOT 50/100cc 2t

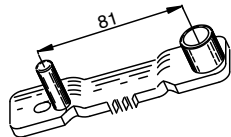

Art. 5580

PER MOTORI / FOR ENGINES
KYMCO 50cc 2t

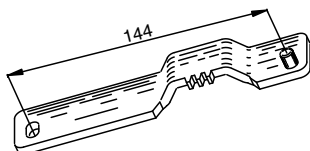

Art. 5582

PER MOTORI / FOR ENGINES
KYMCO AGILITY 50 cc 4t

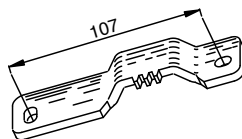

Art. 5454

PER MOTORI **SCOOTER 50cc 2t** DI FABBRICAZIONE
CINESE (MODELLO QJ)
FOR **50cc 2s** CHINESE **SCOOTER** ENGINES (QJ MODEL)
MALAGUTI 50 AIR - CPI - KEEWAY - GENERIC
e altri / and others

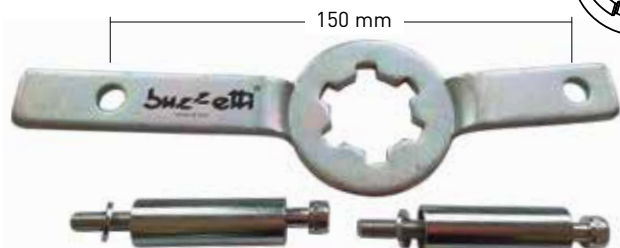
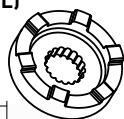

Art. 5497

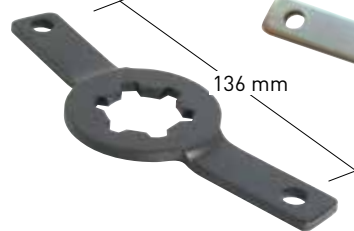

Art. 5496

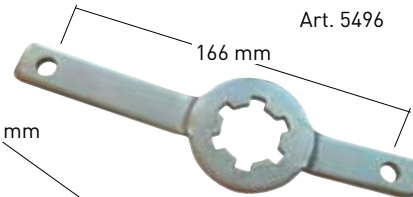

Art. 5496

MOTORI / ENGINES
YAMAHA-MINARELLI 50cc 2t
CILINDRO ORIZZONTALE / HORIZONTAL CYLINDER

Art. 5497

MOTORI / ENGINES
YAMAHA-MINARELLI 50cc 2t
CILINDRO VERTICALE / VERTICAL CYLINDER

Art. 5437

MOTORI / ENGINES 4t 3V
VESPA PRIMAVERA 125-150cc
VESPA SPRINT 125 - 150cc
PIAGGIO LIBERTY 125 - 150cc

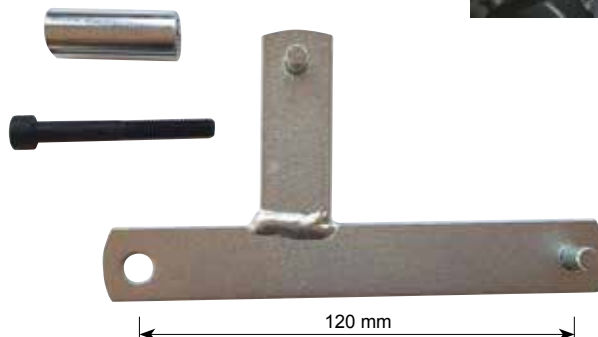

Art. 5440

PER MOTORI / FOR ENGINES
PIAGGIO 125/150 4t 3V



ATTREZZI PER BLOCCARE LA ROTAZIONE DELLA PULEGGIA ANTERIORE FRONT PULLEY LOCKING TOOL - PREVENT PULLEY ROTATION

Art. 5442

PER MOTORI / FOR ENGINES
PIAGGIO 250-300cc 4t
LC - GTS - GTV / QUASAR
APRILIA SPORT CITY 300cc 4t



Art. 5509

PER MOTORI / FOR ENGINES
SYM 50cc 4t - FIDDLE - SYMPHONY
PEUGEOT TWEET 50cc

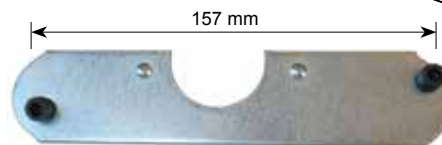

Art. 5446

PER MOTORI **PIAGGIO 400-500cc 4t**
FOR **PIAGGIO 400-500cc 4s** ENGINES

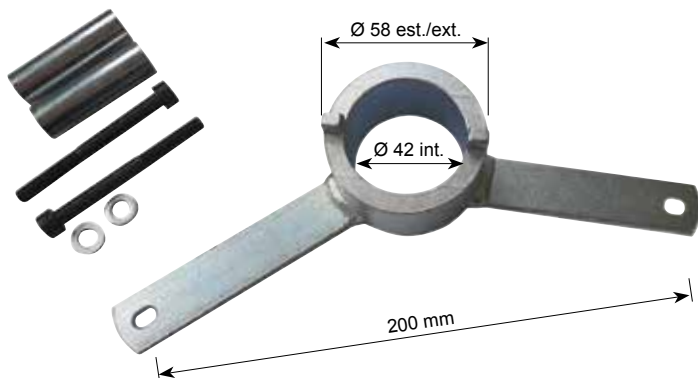

Art. 5554

PER MOTORI / FOR ENGINES
HONDA - HONDA SH 125/150
KYMCO - KEEWAY
CPI/GENERIC 6 MARCE / 6 GEARS
Scooter 50/125/150/300 2t-4t

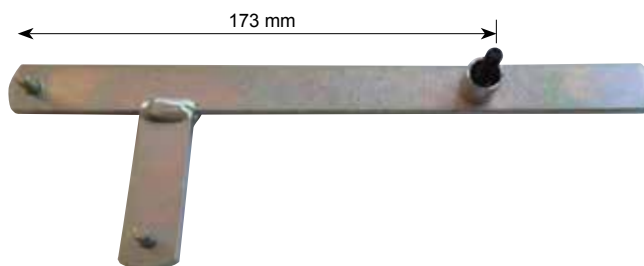

Art. 5462

PER MOTORI **SUZUKI 125/150cc 4t**
FOR **SUZUKI 125/150cc 4s** ENGINES
SCOOTER SIXTEEN

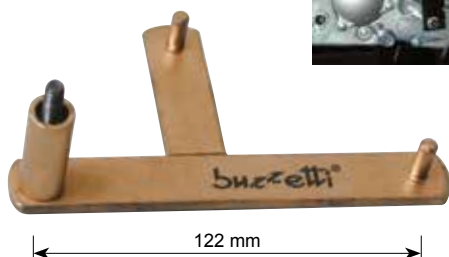

Art. 5702

PER MOTORI / FOR ENGINES
LML STAR 125/150/151/200 4t

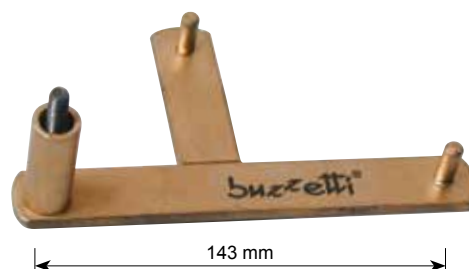

ATTREZZO BLOCCA VOLANO MAGNETICO TOOL TO LOCK THE MAGNETIC FLY-WHEEL

Art. 5516

PER MOTORI / FOR ENGINES
YAMAHA XENTER 125 / 150cc 4t

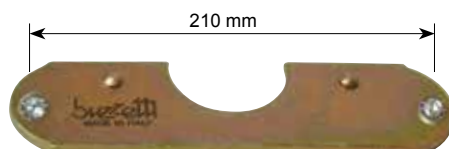

Art. 5504

YAMAHA - MINARELLI 50/100 2t
PEUGEOT 50 2t



ATTREZZI PER IL BLOCCAGGIO DELLA ROTAZIONE DELLA CAMPANA FRIZIONE, DELLA PULEGGIA ANTERIORE E DEL VOLANO CLUTCH PULLEY, FRONT PULLEY AND FLYWHEEL LOCKING TOOL



Art. 5636

ATTREZZO CON DENTELLI PIATTI E DENTELLI TONDI DA Ø 8MM CON BLOCCAGGIO DELL'APERTURA

CAPACITA' MAX. 130mm
PESO 0,750 KG

HOLDING TOOL WITH FLAT NOTCHES AND CIRCULAR TEETH OF Ø 8mm

130mm MAX. CAPACITY
WEIGHT 0,750 KG

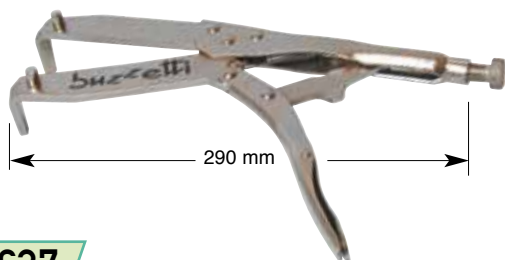

Art. 5637

ATTREZZO UNIVERSALE CON DENTELLI DA Ø 5mm E Ø 9mm

CAPACITA' MAX. 140mm
PESO 0,485 KG

UNIVERSAL TOOL WITH Ø 5mm AND Ø 9mm NOTCHES

140mm MAX. CAPACITY
WEIGHT 0,485 KG

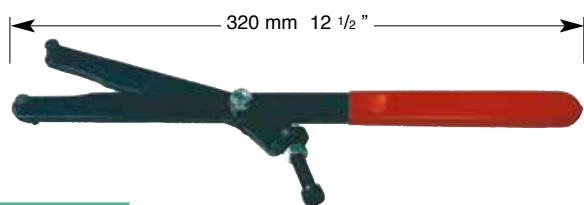

Art. 5638

ATTREZZO CON DENTELLI A SMUSSO PER BLOCCARE LA ROTAZIONE DI CORPI DENTATI

CAPACITA' MAX. 125 mm
PESO 0,620 KG

TOOL WITH BLUNTED NOTCHES TO LOCK THE ROTATION OF TOOTHED PARTS

125 mm MAX. CAPACITY
WEIGHT 0,620 KG

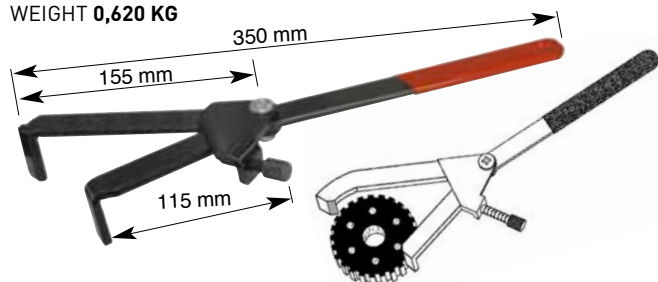

Art. 5528

PER / FOR

YAMAHA TMAX 500 - 530

ATTREZZO CON 4 PIOLI PER BLOCCARE LA PULEGGIA POSTERIORE E 2 PIOLI PER LA PULEGGIA ANTERIORE

PESO 1 KG

TOOL WITH 4 PINS TO LOCK THE REAR PULLEY AND 2 PINS FOR THE FRONT PULLEY

WEIGHT 1 KG



Art. 0312

ATTREZZO PER LA REGOLAZIONE DELLA TENSIONE DELLE CINGHIE DENTATE

VEDERE PAG. 60

ISTRUZIONI CON L'ATTREZZO

TENSIONING GAUGE TOOL FOR TIMING BELTS

SEE PAGE 60

USER INSTRUCTIONS INCLUDED

per / for **YAMAHA TMAX 530**



Art. 5428

ATTREZZO BLOCCA FRIZIONE

per **PIAGGIO 125-250-300cc 4t**

CLUTCH LOCKING TOOL

for **PIAGGIO 125-250-300cc 4s**

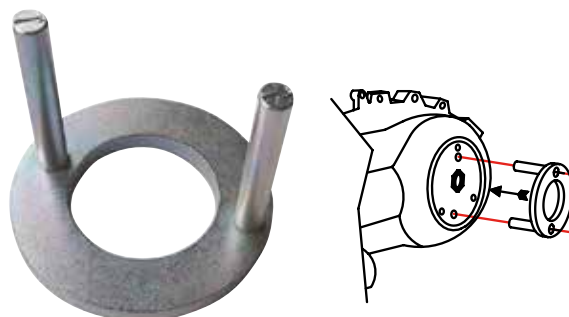

Art. 5633

ATTREZZO UNIVERSALE PER IL BLOCCAGGIO DELLA ROTAZIONE DELLA CAMPANA FRIZIONE PER SCOOTER DA 125cc A 500cc
CAPACITA' DA Ø 100 A Ø 255 mm
UNIVERSAL TOOL TO HOLD CLUTCH PULLEY ROTATION FOR SCOOTER FROM 125cc TO 500cc
CAPACITY FROM Ø 100 TO Ø 255 mm

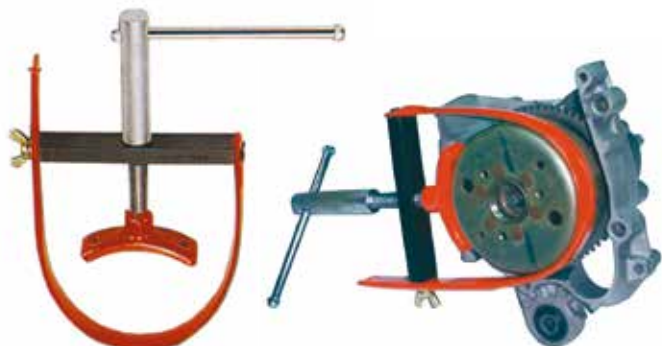

Art. 5635

ATTREZZO UNIVERSALE PER IL BLOCCAGGIO DELLA ROTAZIONE DELLA CAMPANA FRIZIONE DA 50cc A 125cc
CAPACITA' DA Ø 45 A Ø 120mm
UNIVERSAL TOOL TO HOLD CLUTCH PULLEY ROTATION FROM 50cc TO 125cc
CAPACITY FROM Ø 45 TO Ø 120mm



ATTREZZO BLOCCA FRIZIONE
CON ESAGONO
TOOL TO LOCK THE CLUTCH
WITH HEXAGON



Art. 5427

PIAGGIO - VESPA - GILERA
APRILIA - 50 2t-4t
TUTTI I MODELLI / ALL MODELS
ES./HEX. mm. 34

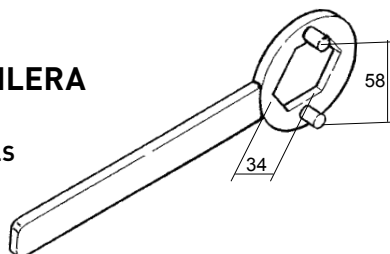

Art. 5476

YAMAHA - MBK 50 2t
MALAGUTI 50 2t - KYMCO 50 2t-4t
PEUGEOT 50 2t
SUZUKI 50 2t
ES./HEX. mm. 39

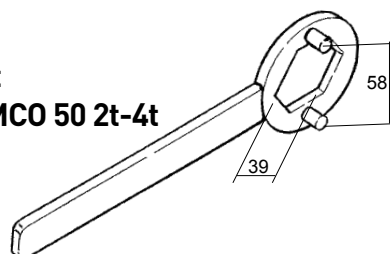

Art. 5495

YAMAHA - MBK 50 2t
MALAGUTI 50 2t - KYMCO 50 2t
PEUGEOT 50 2t
SUZUKI 50 2t
ES./HEX. mm. 38

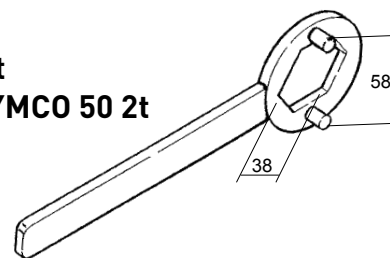

Art. 5499

YAMAHA - MBK 50 2t
MALAGUTI 50 2t - KYMCO 50 2t
PEUGEOT 50 2t
SUZUKI 50 2t
ES./HEX. mm. 41

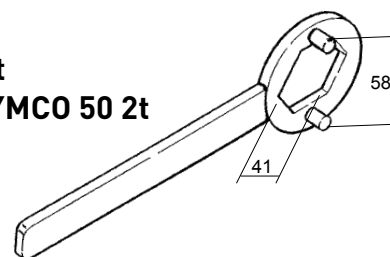

Art. 5506

Per motori / for YAMAHA - MINARELLI engines
scooter 125/150/200 4t
YAMAHA XENTER 125/150
ES./HEX. mm. 46

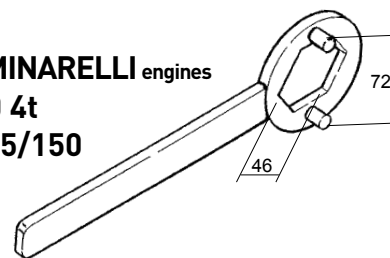

CHIAVE PER DADO VARIATORE POSTERIORE
REAR VARIATOR NUT WRENCH

Art. 5445

ES./HEX. mm. 46
per/for PIAGGIO 250cc - YAMAHA 125-150cc

Art. 5449

ES./HEX. mm. 55
per/for PIAGGIO da/from 300cc a/to 500cc

**RITEGNO MOLLA FRIZIONE
CLUTCH SPRING TOOL**

Art. 5650

ATTREZZO RITEGNO MOLLA FRIZIONE PER MOTORI CON PULEGGIA Ø mm 125 MAX.

CLUTCH SPRING CHECK-TOOL FOR ENGINES WITH Ø mm 125 MAX PULLEY.

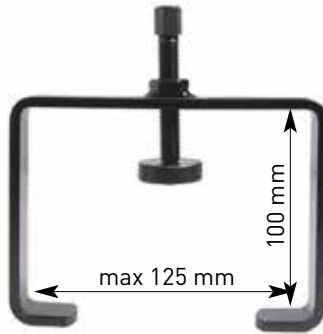
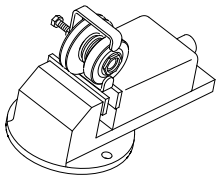

Art. 5656

**ATTREZZO RITEGNO MOLLA FRIZIONE PER MOTORI CON PULEGGE GRANDI
CLUTCH SPRING CHECK-TOOL FOR ENGINES WITH BIG PULLEYS**

CAPACITA' / CAPACITY 220mm

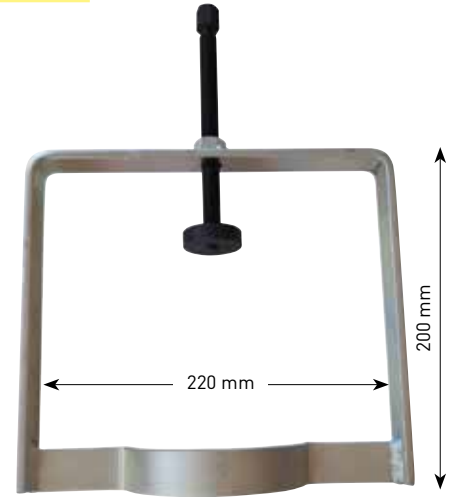
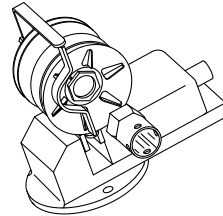

Art. 5654

ATTREZZO RITEGNO MOLLA FRIZIONE PER MOTORI CON PULEGGIA Ø mm 155 MAX.

CLUTCH SPRING CHECK-TOOL FOR ENGINES WITH Ø mm 155 MAX PULLEY.

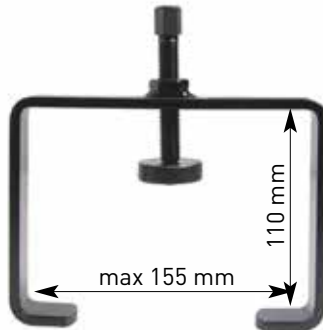
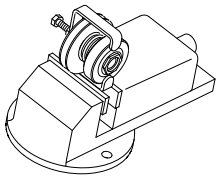

Art. 5658

**ATTREZZO RITEGNO MOLLA FRIZIONE
CLUTCH SPRING CHECK TOOL
PER MOTORI / FOR ENGINES
PIAGGIO - VESPA
DA/FROM 125cc A/TO 500cc 4t**

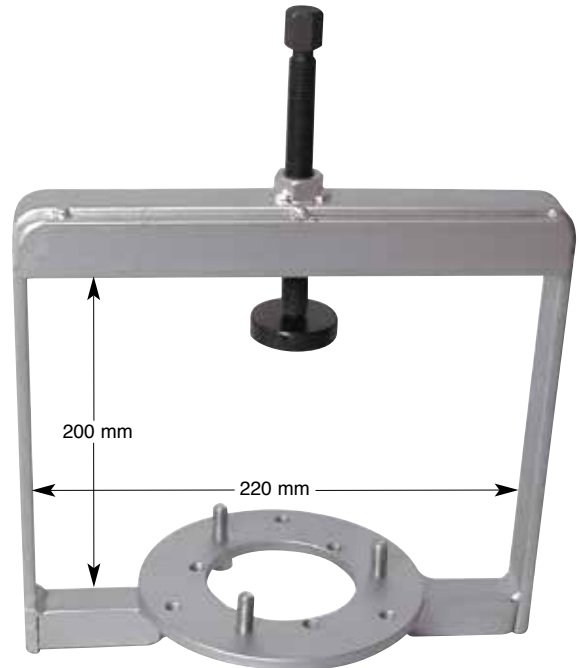

ATTREZZI PER MANUTENZIONE CATENA MAINTENANCE CHAIN TOOLS

Art. 4988

ATTREZZO SMONTAGGIO/MONTAGGIO CATENE CON VITI A PUNTALE E PUNZONE RIVETTATORE.

COMPLETO DI VITE A PUNTA CONICA PER LA RIVETTATURA DEL PIOLO FORATO.

PER CATENE RIF. 415-420-428-520-525-530-532.
ISTRUZIONI D'USO NELLA CONFEZIONE.

DISASSEMBLING/ASSEMBLING SEALED CHAINS TOOL WITH PUSH ROD SCREWS AND RIVETING PUNCH.

EQUIPPED WITH CONICAL POINT SCREW FOR DRILLED PIN RIVETING FOR CHAINS REF. 415-420-428-520-525-530-532.

USER INSTRUCTIONS INCLUDED.



Art. 4991

COPPIA VITI DI RICAMBIO PER ART. 4992

COUPLE OF SPARES SCREWS FOR ART. 4992

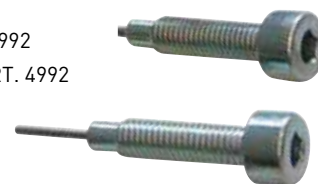

Art. 4983

SET 3 VITI DI RICAMBIO PER ART. 4988

VITI DA M16 CON SPINA CORTA E CON SPINA LUNGA

VITE A PUNTA CONICA PER LA RIVETTATURA DEL PIOLO FORATO

3 SPARES SCREWS FOR ART. 4988

M16 SCREWS WITH SHORT AND LONG PIN

CONICAL POINT SCREW FOR OPENING CHAINS WITH DRILLED PIN



Art. 4984

PUNZONE RIVETTATORE DI RICAMBIO

PER ART. 4988

REPLACEMENT PUNCH RIVETING TOOL

FOR ART. 4988



Art. 4992

ATTREZZO SMONTAGGIO/MONTAGGIO CATENA DI DISTRIBUZIONE

ISTRUZIONI D'USO NELLA CONFEZIONE.

ENGINE TIMING CHAIN DISASSEMBLING/ASSEMBLING TOOL

USER INSTRUCTIONS INCLUDED.

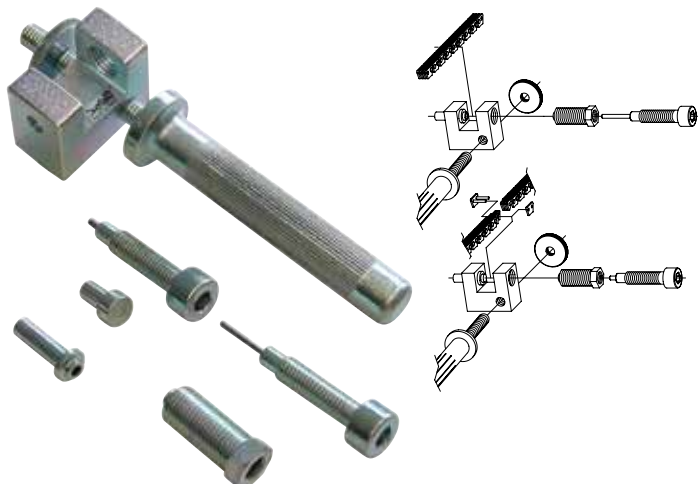

Art. 4994

ATTREZZO SMONTAGGIO/RIMONTAGGIO CATENE

KIT PER CATENA DISTRIBUZIONE, CATENA CICLOMOTORE, CATENA MOTOCICLI.

CON PUNZONI ESPULSORI Ø 2,2 - 2,9 - 3,8 mm.

PUNZONE RIVETTATORE, GUIDAPUNZONI, ALLINEATORI PER CATENA E ACCESSORI DI MANOVRA.

ISTRUZIONI D'USO NELLA CONFEZIONE.

CHAIN BREAKER AND RIVETING TOOL KIT

KIT FOR ENGINE TIMING CHAIN, MOPED CHAIN, MOTORCYCLES CHAIN. WITH BREAKING TIPS Ø 2,2 - 2,9 - 3,8 mm.

RIVET TIP, TIP GUIDES, ALIGNMENTS BOLTS AND USER ACCESSORIES. USER INSTRUCTIONS INCLUDED.



Art. 4995

ROBUSTO ATTREZZO SMONTAGGIO/MONTAGGIO CATENE
PER CATENE RIF. 520-525-530.

HEAVY-DUTY DISASSEMBLING/ASSEMBLING CHAINS TOOL KIT
FOR CHAINS REF. 520-525-530.



Art. 4989

ATTREZZO ROMPICATENA
PER CATENE RIF. 415, 420, 428, 520, 525, 530, 532
ISTRUZIONI D'USO NELLA CONFEZIONE.

CHAIN BREAKER TOOL
FOR CHAINS REF. 415, 420, 428, 520, 525, 530, 532
USER INSTRUCTIONS INCLUDED.



Art. 4990

MINI PRESSA PER IL RIMONTAGGIO DELLE CATENE
MINI TOOL TO REASSEMBLE THE CHAINS

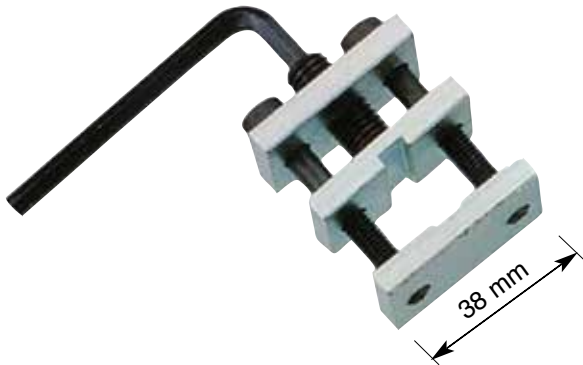

Art. 4998

SPAZZOLINO PULISCI CATENA
CON SPAZZOLE REGOLABILI
CHAIN CLEANER
WITH ADJUSTABLE BRUSHES

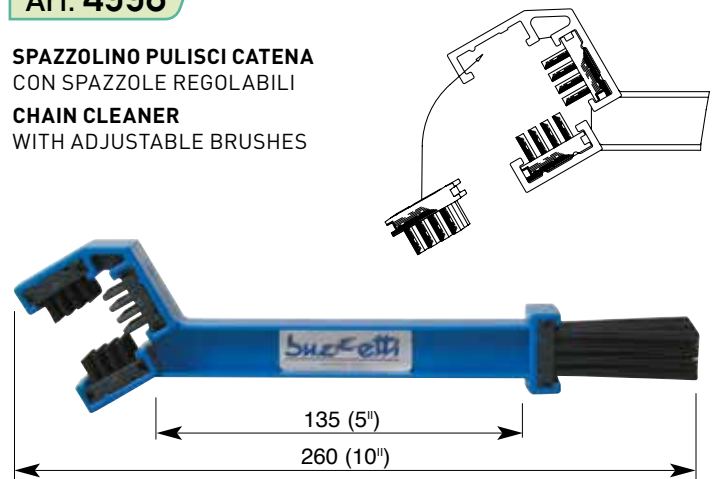

ATTREZZI PER FRENI E FORCELLE TOOLS FOR BRAKES AND FORKS

Art. 5125

ATTREZZO ALLARGA PINZA FRENO

BECCHI DA 42mm -
APERTURA 48mm

OPEN BRAKE DISK TOOL -

42mm BEAKS - OPENING 48mm

A = da/from 120mm
a/to 170mm

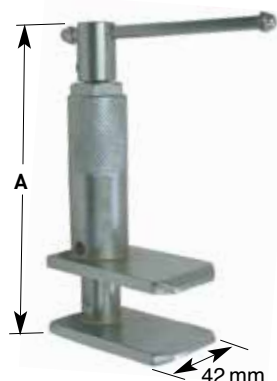

Art. 5132

ATTREZZO CON ESPANSORI GRIPPANTI PER RIMUOVERE IL PISTONCINO DEL FRENO

CAPACITA' DA Ø 15 A Ø 28 mm

BRAKE PISTON REMOVAL TOOL

WITH SEIZENING EXPANDERS
CAPACITY FROM Ø 15 TO Ø 28 mm



Art. 5127

ATTREZZO ALLARGA PINZA FRENO

BECCHI DA 50mm
APERTURA 70mm

OPEN BRAKE DISK TOOL

LENGHT NOSE 50mm
OPENING 70mm



Art. 9181

ATTREZZO A 4 ESAGONI PER BLOCCARE IL PERNO DELLA RUOTA ANTERIORE

CON ESAGONO DA 17 - 19 - 22 - 24 MM

4 HEXAGONES TOOL FOR LOCKING THE FRONT WHEEL AXLE

WITH 17 - 19 - 22 - 24 MM HEXAGON



Art. 5130

PINZA REGOLABILE PER STACCARE E RIMONTARE IL PISTONCINO DEL FRENO

CAPACITÀ; 30 - 33 mm
LUNGHEZZA PINZA 240 mm

BRAKE PISTON ADJUSTABLE PLIER TO DETACH AND REPLACE THE BRAKE PISTON

CAPACITY: 30 - 33 mm
PLIER LENGTH 240 mm

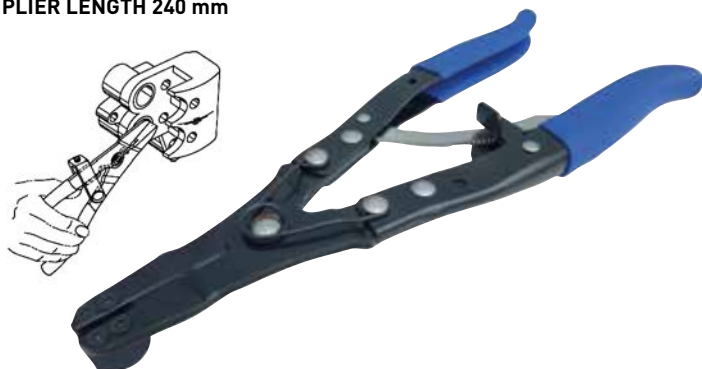

Art. 9184

ATTREZZO A 6 ESAGONI PER BLOCCARE IL PERNO DELLA RUOTA ANTERIORE

CON ESAGONI DA 12 - 14 - 17 - 19 - 22 - 24 MM

6 HEXAGONES TOOL DESIGNED FOR LOCKING THE FRONT WHEEL AXLE

WITH 6 DIFFERENT SIZES 12 - 14 - 17 - 19 - 22 - 24 MM



Art. 8996

ATTREZZO PER AGGANCIARE L'ASTA DELL'AMMORTIZZATORE DOPO L'INSTALLAZIONE DELLA MOLLA

CON ADATTATORI DA M10x1 ; M12x1 ; M12x1,25 ; M14x1
ADATTO PER FORCELLE KAYABA - SHOWA - WP

DAMPING ROD TOOL TO RETRIEVE THE FORK'S ROD AFTER SPRING INSTALLATION

WITH M10x1 ; M12x1 ; M12x1,25 ; M14x1 ADAPTERS
WORKS ON KAYABA - SHOWA - WP FORKS



**ATTREZZO BLOCCA POMPANTE FORCELLE IDRAULICHE
DAMPER ROD LOCK TOOL FOR HYDRAULIC FORKS**

Art. 9100

PUNTALE A CROCE Ø DA 5 A 13 MM - LUNGHEZZA 340 MM
CROSS HEAD POINT Ø FROM 5 TO 13 MM - LENGHT 340 MM

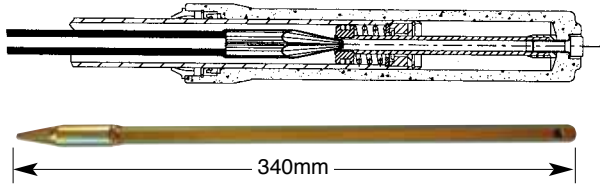

Art. 9102

PUNTALE A CROCE Ø DA 14 A 17 MM - LUNGHEZZA 600 MM
CROSS HEAD POINT Ø FROM 14 TO 17 MM - LENGHT 600 MM

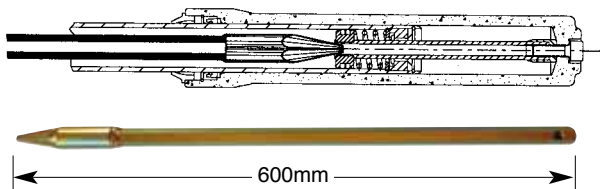

Art. 9115

ATTREZZO AUSILIARIO PER SMONTARE/RIMONTARE IL BRACCIO DELLE
FORCELLE A STELI ROVESCIA TI
ISTRUZIONI NELLA CONFEZIONE
AUXILIARY UPSIDE DOWN FORKS ASSEMBLING/DISASSEMBLING TOOL
USER INSTRUCTION INCLUDED



Art. 4943

SET DI 3 ATTREZZI PER RIMUOVERE GUARNIZIONI, O-RING,
TUBI FLESSIBILI E ALTRO

SET OF 3 REMOVER TOOLS FOR SEAL, O-RINGS, FLEXIBLE
HOSES AND OTHER



**ATTREZZI PER RIMUOVERE LE GUARNIZIONI
SEAL PULLER TOOLS**

Art. 9117

PER / FOR
Ø 20 - 60 mm



Art. 9119

PER / FOR
Ø 20 - 90 mm



Art. 5091

SPURGATORE DELL'OLIO DEL SISTEMA FRENANTE
ISTRUZIONI CON IL KIT

BRAKE OIL BLEEDING DEVICE USER
INSTRUCTION INSIDE THE PACKAGING



Art. 5092

MISURATORE LIVELLO OLIO DELLE FORCELLE

PER CONTROLLARE E RIPRISTINARE IL LIVELLO.
UTILE PER LA RICARICA DELL'ESATTA QUANTITA' NECESSARIA.
CAPACITÀ SIRINGA 70 cc
ISTRUZIONI CON IL KIT.

FORK OIL LEVEL GAUGE

TO CHECK AND GAUGE THE LEVEL.
USEFUL TO REFILL THE CORRECT QUANTITY.
SYRINGE CAPACITY 70 cc
USER INSTRUCTION INSIDE THE PACKAGING.



Art. 5094

SET DI CHIAVI PER APRIRE / CHIUDERE LA VITE SPURGO FRENI

COMPLETO DI CHIAVI DA 8 - 10 - 11 MM
TUBO IN SILICONE DA 1,2 mt CON VALVOLA DI SICUREZZA

BRAKE BLEEDER WRENCH SET WITH CHECK VALVE FOR LOOSENING / TIGHTENING BLEED NIPPLES

WITH 8 - 10 - 11 mm WRENCHES, 1,2 mt SILICON HOSE WITH SAFETY CHECK VALVE



Art. 5093

ATTREZZO PER SCARICARE L'OLIO DEI FRENI

PER IL CAMBIO DELL'OLIO NELL'IMPIANTO FRENANTE. LA PARTICOLARE VALVOLA PERMETTE AL FLUIDO DI FUORIUSCIRE IMPEDENDO ALLE BOLLE D'ARIA DI ENTRARE NEL SISTEMA FRENANTE

BRAKE BLEEDING TOOL

IT MAKES EASIER THE BLEEDING OF BRAKES. THE SPECIAL VALVE PREVENTS AIR RETURNING INTO THE BRAKE SYSTEM WHILE BRAKE BLEEDING



Art. 5396

CHIAVE POLIGONALE DA 30 e 32 mm PER DADO TESTA FORCELLA MOTOCICLI

30 - 32 mm POLYGONAL MOTORCYCLES FORK CAP WRENCH



CHIAVE PER DADI BRACCI FORCELLA

FORK CAPS WRENCH

Art. 5400

CON OTTAGONI DA 46 E 50 mm
WITH 46 AND 50 mm OCTAGONS

Art. 5402

CON OTTAGONI DA 49 E 50 mm
WITH 49 AND 50 mm OCTAGONS



ATTREZZO PIANTAGGIO GUARNIZIONE FORCELLA FORK SEAL DRIVER TOOL

TIPO APERTO
OPEN TYPE



Art. 9145 STELI / STEMS \varnothing 35 / 36

Art. 9146 STELI / STEMS \varnothing 37

Art. 9147 STELI / STEMS \varnothing 38

Art. 9149 STELI / STEMS \varnothing 40

Art. 9150 STELI / STEMS \varnothing 41

Art. 9152 STELI / STEMS \varnothing 43

Art. 9154 STELI / STEMS \varnothing 45

Art. 9155 STELI / STEMS \varnothing 46 / \varnothing 47

Art. 9157 STELI / STEMS \varnothing 48

Art. 9159 STELI / STEMS \varnothing 49 / \varnothing 50

Art. 9165

SET DI PIANTAGGI GUARNIZIONE FORCELLA
CON 6 DIFFERENTI ADATTATORI DA
 \varnothing 35 / 36 - 40 / 41 - 42 / 43 - 45 / 46 - 47 / 48 - 49 / 50
E FLANGIA DI ACCOPPIAMENTO

FORK SEALS DRIVER TOOLS SET
WITH 6 DIFFERENT SIZES ADAPTERS
 \varnothing 35 / 36 - 40 / 41 - 42 / 43 - 45 / 46 - 47 / 48 - 49 / 50
AND OPERATING FLANGE



CHIAVE TIRARAGGI COMPONIBILE - A DUE INNESTI
UNITS SPOKE WRENCH - DOUBLE SOCKETS

Art. 4884 SOLO MANICO / ONLY HANDLE

Art. 4886 INNESTO / SOCKET mm. 5

Art. 4889 INNESTO / SOCKET mm. 5,6

Art. 4890 INNESTO / SOCKET mm. 5,8

Art. 4891 INNESTO / SOCKET mm. 6

Art. 4893 INNESTO / SOCKET mm. 6,4

Art. 4895 INNESTO / SOCKET mm. 6,8

Art. 4896 INNESTO / SOCKET mm. 6,9

Art. 4921

CHIAVE TIRARAGGI A 6 IMBOCCHI
SPOKE WRENCH WITH 6 OPEN END
mm 5,6 - 5,7 - 6 - 6,3 - 6,6 - 6,8



Art. 4920

CHIAVE TIRARAGGI DINAMOMETRICA
CON 8 INNESTI DA 5.1mm., 5.8mm., 6.1mm., 6.3mm., 6.4mm., 6.5mm.,
6.7mm., 6.9mm., INNESTO A 6 SCANALATURE E MANICO FISSO
CAPACITÀ DI SERRAGGIO 2-7 Nm

DYNAMOMETRICAL SPOKE TORQUE WRENCH
WITH 8 SPOKE HEADS OF 5.1mm., 5.8mm., 6.1mm., 6.3mm., 6.4mm., 6.5mm.,
6.7mm., 6.9mm., ONE SPOKE HEAD-6PT SPLINE AND FIXED HANDLE
2-7 Nm TORQUE CAPACITY



**LEVAGOMMA CON RIVESTIMENTO IN NYLON
TYRE LEVER WITH NYLON COATING**

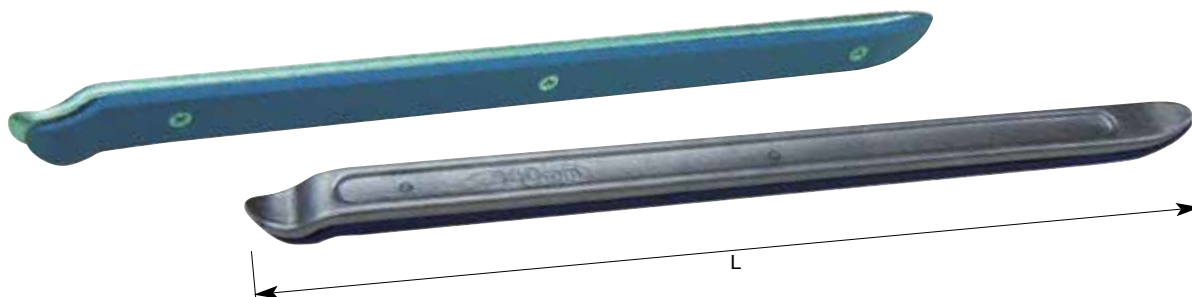

Art. 4966

L = MM 380
IN ACCIAIO AL CARBONIO - PESO 0,420 KG
IN CARBON STEEL - WEIGHT 0,420 KG

Art. 4967

L = MM 500
IN ACCIAIO AL CROMO VANADIO - PESO 0,735 KG
IN CHROME VANADIUM STEEL - WEIGHT 0,735 KG

Art. 4970



**LEVAGOMMA PER PNEUMATICI TALLONATI
ACCIAIO AL CROMO MOLIBDENO - PESO 0,400 Kg**

**TYRE TOOL FOR OFF-ROAD TYRES
CHROME MOLYBDENUM STEEL - WEIGHT 0,400 Kg**

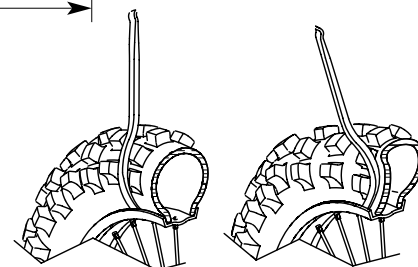

Art. 4971



LEVAGOMMA EXTRALUNGO L = 530 mm
IN ACCIAIO AL CROMO VANADIO - PESO 0,965 KG
CON PROTEGGI CERCHIONE SCORREVOLE IN NYLON

EXTRA LONG TYRE LEVER L = 530 mm
IN CHROME VANADIUM STEEL - WEIGHT 0.965 KG
WITH RIM NYLON PROTECTIVE SLEEVE

Art. 9220

**PROTEGGI CERCHIONE SCORREVOLE IN NYLON PER ART. 4971
RIM NYLON PROTECTIVE SLEEVE FOR ART. 4971**



Art. 4965

NEW

**LEVAGOMMA IN ACCIAIO MM. 440 CON IMPUGNATURA
TYRE LEVER IN STEEL MM. 440 WITH HANDLE**



**DISPONIBILE DA APRILE 2023
AVAILABLE FROM APRIL 2023**

Art. 4956

SERIE LEVAGOMMA DI mm. 170

In acciaio al carbonio forgiata, con impugnatura plasticata, serie di n. 3 pezzi

Tyre tool in carbonium steel, with plasticized handle, lenght mm. 170, set of n. 3 pcs.

Conf. / Pack 1 set

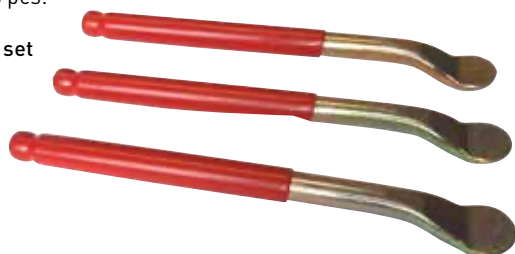

Art. 4959

LEVAGOMMA DI mm. 200

In acciaio al carbonio – Peso Kg. 0,145

In carbonium steel – Weight Kg. 0145

Conf. / Pack 5 pcs

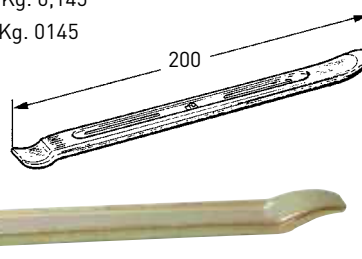

Art. 4953

NEW

LEVAGOMMA DI mm. 200

In acciaio al carbonio – Peso Kg. 0,09

In carbonium steel – Weight Kg. 0,09

Conf. / Pack 5 pcs

**DISPONIBILE DA APRILE 2023
AVAILABLE FROM APRIL 2023**

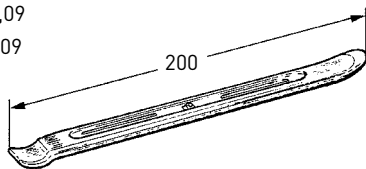

Art. 4955

NEW

SERIE LEVAGOMMA DI mm. 200 – Peso Kg. 0,09 cad.

In acciaio al carbonio, serie di n. 3 pezzi , con gancio di fissaggio al raggio

Tyre tool in carbonium steel, lenght mm. 200 - Weight Kg. 0,09 each, set of 3 pcs. with hook blocking on the spoke

Conf. / Pack 1 pc

DISPONIBILE DA APRILE 2023 - AVAILABLE FROM APRIL 2023



Art. 4960

SERIE LEVAGOMMA DI mm. 200

In acciaio al carbonio, serie di n. 3 pezzi, con gancio di fissaggio al raggio
Tyre tool in carbonium steel, lenght mm. 200 set of n. 3 pcs., with hook blocking on the spoke

Conf. / Pack 1 set

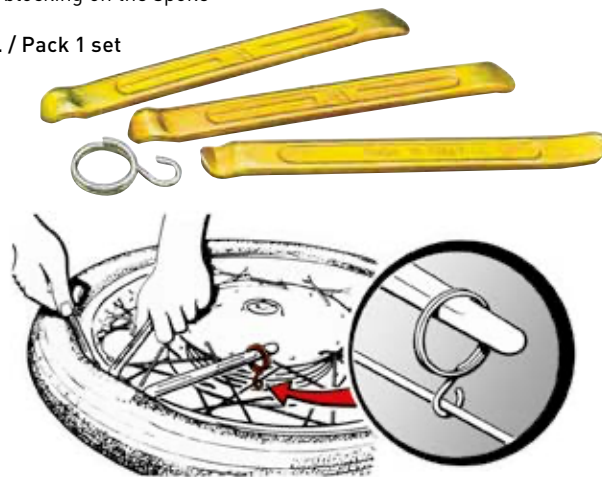

Art. 4962

LEVAGOMMA DI mm. 240

In acciaio cromo

In steel chrome

Conf. / Pack 5 pcs

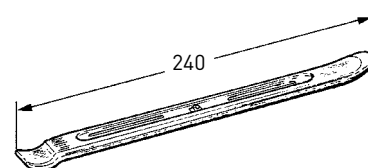

Art. 4963

SERIE LEVAGOMMA DI mm 240

In acciaio al cromo, serie di n. 3 pezzi, con gancio di fissaggio al raggio
Tyre tool in steel chrome, length mm. 240, set of n. 3 pcs., with hook blocking on the spoke

Conf. / Pack 1 set

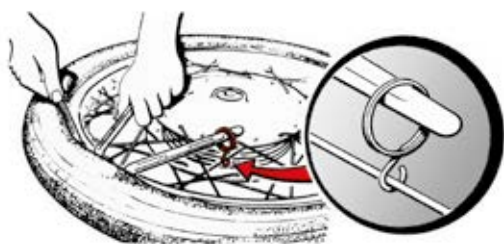

Art. 4968

LEVAGOMMA DI mm. 350 «PROFESSIONAL»

In acciaio al cromo / in steel chrome

Conf. / Pack 1 pc

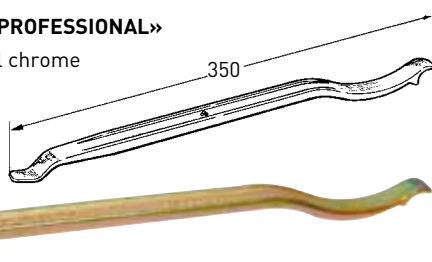

Art. 4969

SERIE LEVAGOMMA «PROFESSIONAL»

Serie formata da n. 2 levagomma di mm. 350 e n. 1 levagomma di mm. 240, in acciaio al cromo, con gancio di bloccaggio al raggio

Tyre tool «PROFESSIONAL» set, type with n. 2 tyre tools mm. 350 and n. 1 tyre tool mm. 240 in steel chrome, with hook blocking on the spoke

Conf. / Pack 1 set

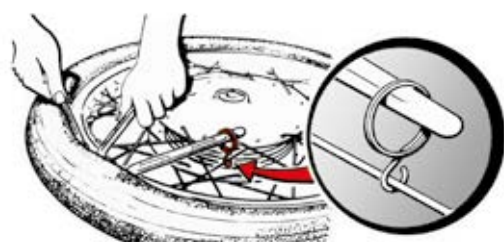

Art. 4974

PINZA STACCA COPERTONE PER TUBE LESS TUBE LESS TYRE CRUSH TOOL BEAD BREAKER

Conf. / Pack 1 pc

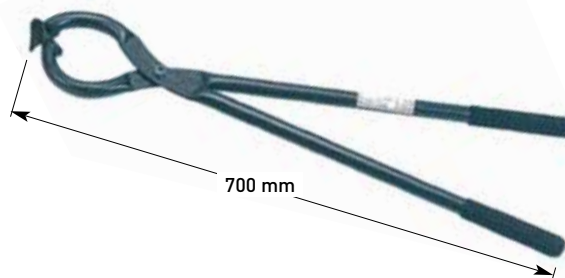

Art. 4976

STACCA COPERTONE DI mm 330

ATTREZZO PER SOLLEVARE IL COPERTONE.
FACILITA L'INSERIMENTO DELLA VALVOLA
PESO Kg 0,290

mm 330 TYRE DETACHING TOOL

USEFUL TO LIFT THE TYRE. IT MAKES EASIER
VALVE INTRODUCTION.
WEIGHT kg. 0,290



Art. 4979

ATTREZZO BLOCCA COPERTONE TOOL TO LOCK THE TYRE BEADS



Art. 4980

ATTREZZO BLOCCA COPERTONE

Facilita il montaggio sulle ruote a raggi
Istruzioni nella confezione

TYRE LOCATING LEVER

Make easier the assembling on spoke wheels
User instruction included

Conf. / Pack 1 pc

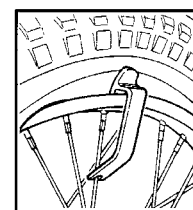

Art. 4972

COPPIA PROTEGGI CERCHIONE IN NYLON PAIR OF NYLON RIM PROTECTORS

Conf. / Pack 1 pc

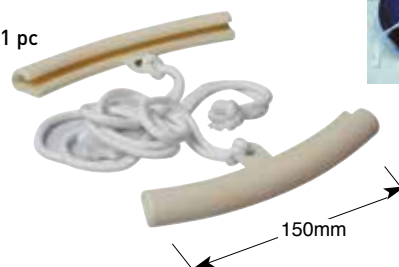

Art. 4973

ATTREZZO MONTAGGIO/SMONTAGGIO VALVOLA DEL PNEUMATICO
TIRA IL GAMBO E TRASCINA NEL FORO LA GUARNIZIONE IN GOMMA
IL MANICO A "T" PERMETTE DI INSTALLARE LA VALVOLA
SENZA SOLLEVARLA OLTRE IL BORDO DEL CERCHIONE

TYRE VALVE ASSEMBLING/DISASSEMBLING TOOL

FOR PULLING RUBBER-COVERED VALVE INTO THE HOLE
T-HANDLE ALLOWS INSTALLING THE VALVE WITHOUT LIFTING
OVER THE RIM EDGE



Art. 4975

ATTREZZO MONTAGGIO/SMONTAGGIO VALVOLA DEL PNEUMATICO CON GAMBO PIEGATO
AGGANCIA IL GAMBO DELLA VALVOLA
LUNGHEZZA TOTALE ATTREZZO : 225 MM

VALVE STEM ASSEMBLING/DISASSEMBLING TOOL

HOLD THE VALVE STEM
TOOL TOTAL LENGTH : 225 MM

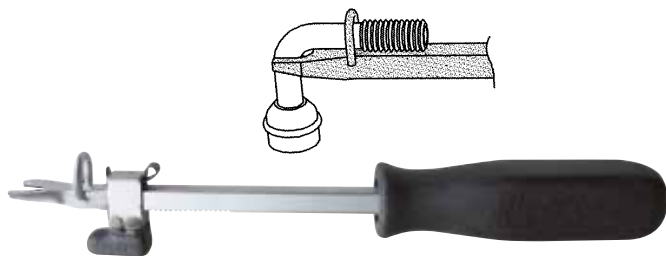

Art. 4977

ATTREZZO PER RIMUOVERE LA VALVOLA DEL PNEUMATICO
UTILE PER SCARICARE RAPIDAMENTE L'ARIA

TYRE VALVE STEM CORE REMOVER

TO DISCHARGE RAPIDLY THE AIR

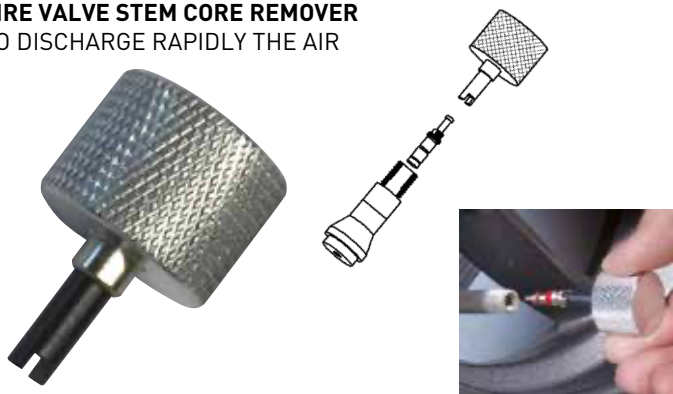

Art. 0700

NEW

KIT RIPARAZIONE PNEUMATICI TUBELESS

LA CONFEZIONE, IN COMODA BORSA DI NYLON, CONTIENE:
1 PUNTERUOLO PER INSERIRE LA STRISCIA DI RIPARAZIONE
1 PUNTERUOLO ELICOIDALE
5 STICK RIPARAZIONE
1 TUBO DI COLLA PER VULCANIZZAZIONE DA 8ML
3 CARTUCCE CO2 DA 16G
1 PROTEZIONE PER CARTUCCIA
1 COLTELLINO
1 RACCORDO FLESSIBILE E IMPUGNATURA

TUBELESS TYRE REPAIR TOOL KIT

THE PACKAGE, IN A HANDY NYLON BAG, CONTENTS :

1 T-HANDLE TO INSERT THE TYRE SEAL
1 HELICAL T-HANDLE
5 TYRE SEALS STICKS
1 VULCANIZED GLUE 8ML
3 CO2 16G CARTRIDGES
1 CARTRIDGE PROTECTION
1 KNIFE
1 EXTENSION TUBE WITH HANDLE



DISPONIBILE DA APRILE 2023

AVAILABLE FROM APRIL 2023

Art. 9181

ATTREZZO A 4 ESAGONI PER BLOCCARE IL PERNO DELLA RUOTA ANTERIORE

CON ESAGONO DA 17 - 19 - 22 - 24 MM

4 HEXAGONES TOOL FOR LOCKING THE FRONT WHEEL AXLE

WITH 17 - 19 - 22 - 24 MM HEXAGON



Art. 9184

ATTREZZO A 6 ESAGONI PER BLOCCARE IL PERNO DELLA RUOTA ANTERIORE

CON ESAGONI DA 12 - 14 - 17 - 19 - 22 - 24 MM

6 HEXAGONES TOOL DESIGNED FOR LOCKING THE FRONT WHEEL AXLE

WITH 6 DIFFERENT SIZES 12 - 14 - 17 - 19 - 22 - 24 MM



Art. 0940

APPOGGIO SOTTORUOTA CON SFERE - GEOMETRIA VARIABILE
FACILITA LA ROTAZIONE MANUALE DELLE RUOTE E LO SPOSTAMENTO DEL MOTOCICLO NELLA ZONA DI ESPOSIZIONE

UNDER-WHEELS BALLS SUPPORT - CHANGEABLE SHAPE
TO MAKE EASIER THE MANUAL ROTATION OF WHEELS AND MOTORCYCLE MOVING INSIDE THE SHOWROOM.

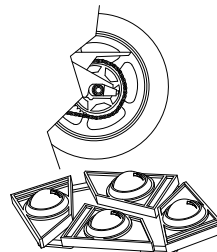

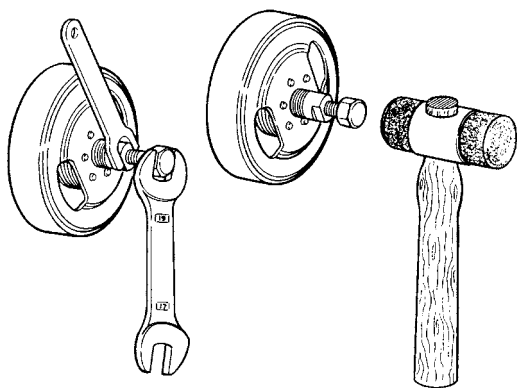

ESTRATTORI CON **FILETTO ESTERNO DESTRO** PER VOLANO MAGNETICO
 PULLERS WITH **RIGHT OUTER THREAD** FOR MAGNETIC FLY-WHEEL



Art. 5208 Ø 18 x p. 1,5

Art. 5209 Ø 19 x p. 1

Art. 5211 Ø 20 x p. 1

Art. 5218 Ø 22 x p. 1

Art. 5219 Ø 22 x p. 1,5

Art. 5220 Ø 22 x p. 1,5

Art. 5224 Ø 24 x p. 1

Art. 5226 Ø 24 x p. 1,5

Art. 5232 Ø 26 x p. 1

Art. 5234 Ø 26 x p. 1,5

Art. 5238 Ø 27 x p. 1

Art. 5239 Ø 27 x p. 1,25

Art. 5242 Ø 28 x p. 1

Art. 5243 Ø 28 x p. 1,25

Art. 5244 Ø 28 x p. 1,5

Art. 5247 Ø 30 x p. 1,5

Art. 5254 Ø 33 x p. 1,5

Conf. / Pack 2 pcs p. = passo / pitch

Art. 5208 Ø mm. 18 passo-pitch 1,5
 YAMAHA CROSS 125/250

Art. 5209 Ø mm. 19 passo-pitch 1
 DUCATI ELETTRONICO

Art. 5211 Ø mm. 20 passo-pitch 1
 PEUGEOT

Art. 5218 Ø mm. 22 passo-pitch 1
 PEDIVELLE CICLO

Art. 5219 Ø mm. 22 passo-pitch 1,5
 BOSCH-DUCATI-MOTOPLATT

Art. 5220 Ø mm. 22 passo-pitch 1,5
CON VITE LUNGA - WITH LONG SCREW
BMW dal/from 2010
 CON VOLANO NIPPODENSO
 WITH NIPPODENSO FLY-WHEEL

Art. 5224 Ø mm. 24 passo-pitch 1
 YAMAHA - MBK - PEUGEOT
 - HONDA - KYMCO 50cc

Art. 5226 Ø mm. 24 passo-pitch 1,5
 IS CRA motori / engines
 MORINI 50cc

Art. 5232 Ø mm. 26 passo-pitch 1
 KOKUSAN - MITSUBA - PIAGGIO
 VESPA - GILERA - APRILIA - PEUGEOT

Art. 5234 Ø mm. 26 passo-pitch 1,5
 BOSCH-MOTOPLATT-SEM-DUCATI

Art. 5238 Estrattore volano Ø mm. 27 passo 1 destro,
 per Honda
 Fly-wheel extractor Ø mm. 27 pitch 1 right
 thread, for Honda
 KOKUSAN

Art. 5239 Ø mm. 27 passo-pitch 1,25
 MOTOPLATT-DUCATI

Art. 5242 Ø mm. 28 passo-pitch 1
 PIAGGIO-GILERA-VESPA
 LML-125-150-200

Art. 5243 Ø mm. 28 passo-pitch 1,25

Art. 5244 Ø mm. 28 passo-pitch 1,5

Art. 5247 Ø mm. 30 passo-pitch 1,5
 MOTOPLATT

Art. 5254 Ø mm. 33 passo-pitch 1,5
 MOTOPLATT-FENSA



ESTRATTORI CON **DOPPIO FILETTO ESTERNO DESTRO** PER VOLANO MAGNETICO

PULLERS WITH **DOUBLE RIGHT OUTER THREAD** FOR MAGNETIC FLY-WHEEL

Conf. / Pack 2 pcs p. = passo / pitch

Art. 5276

Ø mm. 19 p1 - Ø mm. 22 p1,5
DUCATI-BOSCH
per / for MBK-DERBY-RIEJU

Art. 5278

Ø mm. 22 p1,5 - Ø mm. 26 p1,5
BOSCH - DUCATI

Art. 5280

Ø mm. 24 p1 - Ø mm. 26 p1
per / for MBK

Art. 5283

Ø mm. 26 p1 - Ø mm. 28 p1
PIAGGIO - VESPA 125/150 2t-4t

Art. 5288

Ø mm. 26 p1,5 - Ø mm. 27 p1,25
BOSCH-MOTOPLATT-DUCATI

ESTRATTORI CON **FILETTO ESTERNO SINISTRO** PER VOLANO MAGNETICO

PULLERS WITH **LEFT OUTER THREAD** FOR MAGNETIC FLY-WHEEL

Conf. / Pack 2 pcs p. = passo / pitch

Art. 5250

ESTRATTORE VOLANO Ø mm. 27 passo 1 SINISTRO
FLY-WHEEL PULLER Ø mm. 27 pitch 1 LEFT
KOKUSAN - HONDA-YAMAHA-MINARELLI
SUZUKI-KAWASAKI-PEUGEOT - KYMCO -
SYM -
CPI SCOOTER
PER VOLANI GIAPPONE-CINA
FOR JAPAN-CHINA FLY-WHEEL



Art. 5261

ESTRATTORE VOLANO Ø mm. 18 passo 1 SINISTRO
FLY-WHEEL PULLER Ø mm. 18 pitch 1 LEFT
CPI 50cc 2t
PER VOLANI GIAPPONE-CINA
FOR JAPAN-CHINA FLY-WHEEL



ESTRATTORI CON FILETTO INTERNO PULLERS WITH INTERNAL THREAD

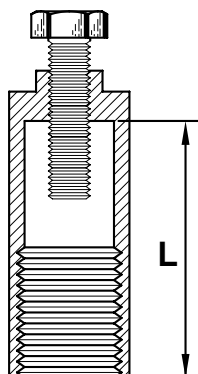

Art. 5304 Ø 22 x p. 1 - L = 70 mm

Art. 5380 Ø 24 x p. 1,5 - L = 75 mm

Art. 5316 Ø 26 x p. 1 - L = 33 mm

Art. 5319 Ø 28 x p. 1 - L = 45 mm

Art. 5345 Ø 28 x p. 1 - L = 45 mm

Art. 5381 Ø 28 x p. 1 - L = 75 mm

Art. 5324 Ø 30 x p. 1 - L = 40 mm

Art. 5337 Ø 30 x p. 1 - L = 91 mm

Art. 5382 Ø 30 x p. 1,25 - L = 75 mm

Art. 5327 Ø 30 x p. 1,5 - L = 40 mm

Art. 5346 Ø 32 x p. 1,25 - L = 22 mm
SINISTRO / LEFT

NEW

Art. 5332 Ø 32 x p. 1,5 - L = 80 mm

Art. 5334 Ø 33 x p. 1,5 - L = 55 mm

Art. 5336 Ø 35 x p. 1 - L = 45 mm

Art. 5340 Ø 35 x p. 1,5 - L = 40 mm

Art. 5343 Ø 38 x p. 1,5 - L = 45 mm

Art. 5344 Ø 39 x p. 1,5 - L = 50 mm

Art. 5330 Ø 42 x p. 1,5 - L = 16 mm
SINISTRO / LEFT

NEW

Conf. / Pack 1 pcs p. = passo / pitch

per / for HONDA

Art. 5304 Ø mm 22 x 1 - L = 70 mm
HONDA CUBE 100

Art. 5319 Ø mm 28 x 1 prod. fino/till 2008
HONDA CROSS 125-250 2t
HONDA MOTARD serie / series
TRX 250-450 4t
KAWASAKI KRX - SUZUKI DRZ

Art. 5327 Ø mm 30 x 1,5
HONDA 125-150-250 4t

Art. 5332 Ø mm 32 x 1,5
Puleggia dentata dell' avviamento
Toothed starter gear
HONDA 125-150 4t scooter

Art. 5334 Ø mm 33 x 1,5
con puntale / with push rod **Art. 5312**
HONDA SH 300 4t - KTM - SUZUKI
- YAMAHA WR - YZ 450 F - BMW

Art. 5380 Ø mm 24 x 1,5
con puntale / with push rod **Art. 5312**
HONDA CRF 250-450 4t
CROSS - ENDURO - SUPERMOTARD

Art. 5381 Ø mm 28 x 1
con puntale / with push rod **Art. 5312**
HONDA CROSS - ENDURO -
MOTARD 125/250 4t
prod. dal/from 2009

Art. 5382 Ø mm 30 x 1,25
con puntale / with push rod **Art. 5312**
HONDA CRF 250-450 4t
CROSS - ENDURO - SUPERMOTARD
KAWASAKI KX - SUZUKI RM -
YAMAHA YZ

per / for KAWASAKI-KYMCO-SUZUKI

Art. 5319 Ø mm 28 x 1
KAWASAKI KLX - SUZUKI DRZ -
HONDA CROSS 125-250 2t
HONDA MOTARD TRX 250-450 4t

Art. 5334 Ø mm 33 x 1,5
con puntale / with push rod **Art. 5312**
SUZUKI - BMW
HONDA SH 300 4t - KTM YAMAHA
WR - YZ 450 F

Art. 5343 Ø mm 38 x 1,5
KAWASAKI KLX - KSF - BMW
SUZUKI DR - BURGMAN -
BOMBARDIER/APRILIA

Art. 5344

Ø mm 39 x 1,5
con puntale filettato / with threaded push rod
Art. 5308
KYMCO 300-500 4t - scooter

Art. 5345

Ø mm 28 x 1
con puntale filettato / with threaded push rod
Art. 5308
KYMCO 250 4t

Art. 5382

Ø mm 30 x 1,25
con puntale / with push rod Art. 5312
KAWASAKI KX - SUZUKI RM -
HONDA CRF 250-450 4t
CROSS-ENDURO-SUPERMOTARD
YAMAHA YZ

per / for **KTM**

Art. 5316

Ø mm 26 x 1
KTM vari modelli/various model
- 125-250 2t

Art. 5330

Ø mm 42 x 1,5 SINISTRO / LEFT **NEW**
KTM DUKE/RC 390

Art. 5334

Ø mm 33 x 1,5
con puntale / with push rod Art. 5312
KTM vari modelli/various model
HONDA SH 300 4t - SUZUKI-
YAMAHA WR - YZ 450 F -
BMW

Art. 5346

Ø mm 32 x 1,25 SINISTRO / LEFT **NEW**
KTM DUKE/RC 125-200

per / for **PIAGGIO**

Art. 5336

Ø mm 35 x 1
volano / fly-wheel DUCATI
per motori / for engines
PIAGGIO 250-400-500 4t

Art. 5337

Ø mm 30 x 1
con puntale / with push rod
VESPA PRIMAVERA 125-150 4t dal/from 2014
VESPA SPRINT 125-150 4t
PIAGGIO LIBERTY 125-150
motori/engines 4t 3V
anche per / also for
VESPA LX 125-150
VESPA S 125-150



per / for **ROTAX**

Art. 5340

Ø mm 35 x 1,5
volano / fly-wheel BOSCH-RCPIIL
per / for ROTAX 125/250
YAMAHA vecchi modelli /old models

per / for **YAMAHA**

Art. 5324

Ø mm 30 x 1
YAMAHA WR-YZ 250 F

Art. 5334

Ø mm 33 x 1,5
con puntale / with push rod Art. 5312
YAMAHA WR-YZ 450 F - BMW
HONDA SH 300 4t - KTM - SUZUKI

Art. 5340

Ø mm 35 x 1,5
volano / fly-wheel BOSCH-RCPIIL
YAMAHA vecchi modelli /old models
ROTAX 125/250

Art. 5382

Ø mm 30 x 1,25
con puntale / with push rod Art. 5312
YAMAHA YZ - HONDA CRF 250-450 4t
CROSS-ENDURO-SUPERMOTARD
KAWASAKI KX - SUZUKI RM

PUNTALI PER ESTRATTORI VOLANO
FLY-WHEEL PULLERS PUSH RODS

Art. 5308

PUNTALE FILETTATO PER VOLANO KYMCO
THREADED PUSH FOR KYMCO FLY-WHEEL

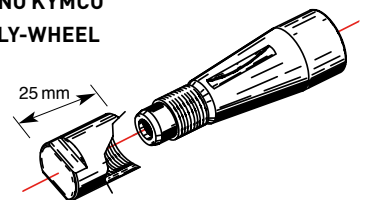

Art. 5312

PUNTALE FILETTATO PER ESTRATTORI HONDA
THREADED PUSH ROD FOR HONDA PULLERS

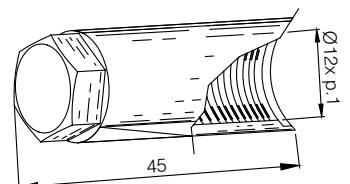

Art. 5360

ESTRATTORE UNIVERSALE

PER LO SMONTAGGIO DEL MOZZO FRIZIONE, DI ALCUNI TIPI DI ALTERNATORE, DI INGRANAGGI E PIGNONI

UNIVERSAL PULLER

TO REMOVE THE CLUTCH HUB, SOME ALTERNATORS, GEARS AND SPROCKETS



Art. 5370

ESTRATTORE VOLANO COMPLETO DI 6 VITI M8X100 E M8X150 CON PUNTALE SALVAFILETTO

FLY WHEEL PULLER COMPLETE WITH 6 SCREWS M8X100 AND M8X150 WITH PROTECTOR CAP

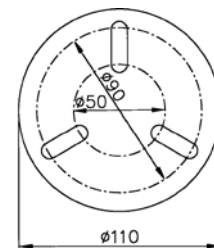
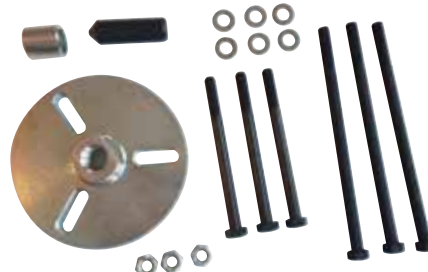

Art. 5362

ESTRATTORE PER VOLANI, ROTORI E INGRANAGGI AVVIAMENTO

COMPLETE WITH 3 SCREWS 6x25, 3 SCREWS 8x40, HANDLE AND CENTRAL SCREW

FLYWHEEL, ROTORS AND STARTER GEARS PULLER TOOL



Art. 5374

ESTRATTORE VOLANO A 4 ASOLE

per motori/for engines SUZUKI - MINARELLI da/from 50 a/till 250cc

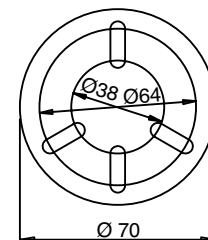

Art. 5358

ESTRATTORE VOLANO MAGNETICO PER MOTORI SUZUKI

COMPLETE WITH 3 SCREWS M5, DRIVE BOLT AND HANDLE

MAGNETIC FLYWHEEL PULLER FOR SUZUKI ENGINES

COMPLETE WITH 3 SCREWS M5, DRIVE BOLT AND HANDLE



Art. 5376

ESTRATTORE VOLANO a 3 viti per motori YAMAHA - MINARELLI - SUZUKI

FLY WHEEL PULLER with 3 screws for YAMAHA - MINARELLI - SUZUKI engines

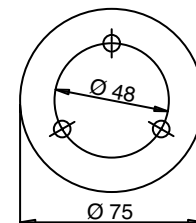

Art. 5491

ESTRATTORE UNIVERSALE Per VOLANI DUCATI - SUZUKI 50cc - per FRIZIONE YAMAHA - MINARELLI 50cc e PUCH 50cc

UNIVERSAL EXTRACTOR For FLY-WHEEL DUCATI - SUZUKI 50 - for YAMAHA - MINARELLI 50cc - PUCH 50cc CLUTCH BODY

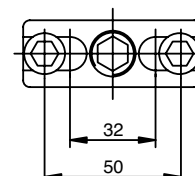



buzzetti®

**RICAMBI - ATTREZZI MOTO E SCOOTER
MOTORCYCLE AND SCOOTER SPARE PARTS - TOOLS**

www.buzzetti.com